

Mitsutomo Submittal Data Sheet

9k BTU Wall Mount High Heat Single Zone

Job Name: _____

Engineer: _____

Submitted By: _____

Date: _____

Unit Tag: _____

System Info & Features:

- Large display handheld remote
- - 24 hr timer
- - Error code diagnosis
- - Functions settings (see manual)
- Economy mode
- Turbo mode
- Dry mode
- Heating down to -22 degrees



MODEL NUMBER	
Indoor unit:	HW-UZ09-AB-Q
Outdoor unit:	HO-SZ09-AB-Q
Certified:	

OPTIONAL ACCESSORIES	
Wifi Adapter	17310900A02901
7 Day Programmable Wall Thermostat	17317100A37597
3rd Party Thermostat Interface Adapter	17222000A68532

SYSTEM PERFORMACE DATA			
Electrical:			
Normal Operational Voltage	(V, Ph, Hz)	208/230V,1Ph,60Hz	
Minimum circuit ampacity (outdoor)	(A)	15.0	
Max fuse (outdoor)	(A)	15.0	
Connection wiring	14AWG*4		
Cooling Efficiencies & Capacity Data:			
Capacity	(Btu/h)	9000(3700~13300)	
Power Input	(W)	569(200~1160)	
Current	(A)	2.5(0.9~5.1)	
SEER2	(Btu/W)	26.4	
EER2	(Btu/W)	15.8	
Heating Efficiencies & Capacity Data:			
Capacity	(Btu/h)	12000(5100~14300)	
Power Input	(W)	902(350~1400)	
Current	(A)	4.0(1.6~6.5)	
HSPF2-4	(Btu/W)	11.6	
HSPF2-5	(Btu/W)	8.5	
COP	W/W	3.90	
Heat at 17F (H32)	(Btu/h)	9300	
Heat at 5F (H42)	(Btu/h)	11000	
COP at 5F (H42)	W/W	1.85	
Temperature Ratings:			
Indoor (cooling)	(Deg. °F)	60~90	
Indoor (heating)	(Deg. °F)	32~86	
Outdoor (cooling)	(Deg. °F)	-22~-122	
Outdoor (heating)	(Deg. °F)	-22~75	

INDOOR UNIT DATA			
Input	(W)		/
Output	(W)		13.0
RLA	(A)		0.2
Speed (Hi/Mi/Lo)	(RPM)		1150 / 990 / 750
Air Flow & Sound Data:			
Indoor air flow (Hi/Med/Lo)	(CFM)		341.18 / 291.18 / 194.12 / 152.94
Indoor noise level (Hi/Med/Lo)	(DBA)		40 / 35 / 23.5
Dry Mode (Dehumidification)	(L/H)		0.4

OUTDOOR UNIT DATA			
Compressor:			
Type	Rotary		
Capacity	(Btu/h)	11823	
Input	(W)	885	
Rated current (RLA)	(A)	8.8	
Outdoor Fan Motor:			
Qty	1		
Input	(W)	/	
Output	(W)	34	
RLA	(A)	0.4	
Speed	(RPM)	850 / 680 / 450	
Airflow & Sound Data:			
Outdoor air flow (Max.)	(CFM)	1324	
Outdoor noise level	(DBA)	55.5	

REFRIGERANT PIPE DATA			
Refrigerant type		R410A	
Refrigerant charge	(oz)	41.62	
Design pressure	(PSIG)	550/340	
Liquid side / Gas side	(inch)	1/4" / 3/8"	
Max. pipe length	(ft)	82.0	
Max. height difference	(ft)	32.8	
Refrigerant Precharge	(ft)	25.0	
Additional charge for each ft	(oz/ft)	0.16	
Connection method	Flared		
Refrigerant oil / oil charge	(ml)	VG74/350	

Dimensions:			
Indoor:			
Dimension (WxDxH)	(inch)		31.57 x 7.87 x 11.61
Packing(WxDxH)	(inch)		34.45 x 11.22 x 14.96
Net/Gross weight	(lbs.)		18.96 / 24.25
Outdoor:			
Dimension (WxDxH)	(inch)		31.69 x 12.99 x 21.81
Packing(WxDxH)	(inch)		36.02 x 14.57 x 24.21
Net/Gross weight	(lbs.)		74.07/80.25

WARRANTY	
	5 years compressor 5 years parts

Outdoor Unit Dimension

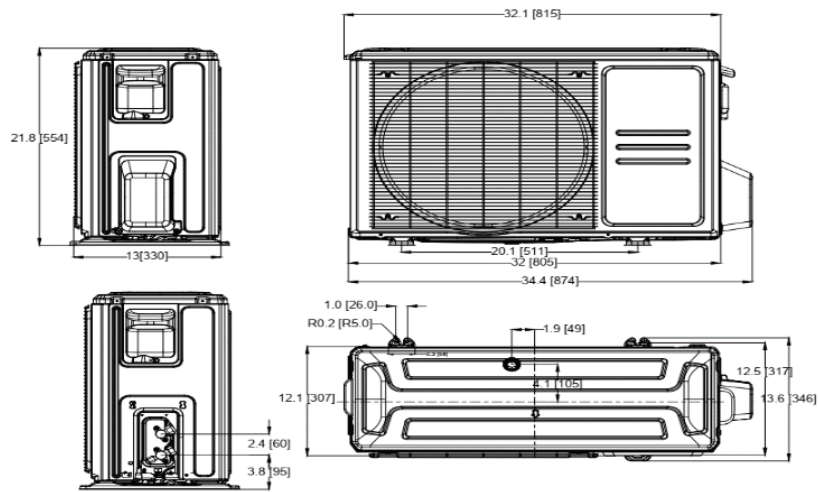

Indoor Unit Dimension (Internal Pump)

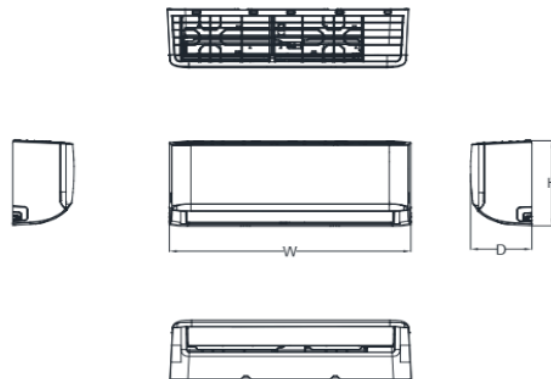

Capacity	W	D	H
9k	31.57	7.87	11.61