

Mitsutomo Submittal Data Sheet

9K High Heat 4 Way Cassette Single Zone Heat Pump System

Job Name: _____

Engineer: _____

Submitted By: _____

Date: _____

Unit Tag: _____

System Info & Features:

- Large display and handheld remote
 - 24 our timer
 - Error code diagnosis
 - Functions settings (see manual)
- Economy Mode
- Turbo Mode
- Dry Mode
- Heating Down to -22 deg
- Fresh Air Intake
- Self Diagnostics
- Super Quiet
- Built in Condensate Pump 25" Lift
- Fits between most 24"x24" Ceiling Tiles
- 7 Day Programmable Wall Thermostat



MODEL NUMBER	
Indoor unit:	HC-UZ09-AB-Q
Outdoor unit:	HO-SZ09-AB-Q
Certified:	

OPTIONAL ACCESSORIES	
3rd Party Thermostat Interface Adapter	17222000A68532
WIFI Adapter	17310900A02901

SYSTEM PERFORMANCE DATA			
Electrical:			
Normal Operational Voltage	(V, Ph, Hz)	208/230V,1Ph, 60Hz	
Minimum circuit ampacity (outdoor)	(A)	15.0	
Max fuse (outdoor)	(A)	15.0	
Connection wiring		14/4 AWG	
Cooling Efficiencies & Capacity Data:			
Capacity	(Btu/h)	9000(2850~11100)	
Power Input	(W)	692(163~1117)	
Current	(A)	3.17(1.25~4.93)	
SEER2	(Btu/W)	20.5	
EER2	(Btu/W)	13.0	
Heating Efficiencies & Capacity Data:			
Capacity	(Btu/h)	9800(2270~12500)	
Power Input	(W)	930(149~1371)	
Current	(A)	4.58(1.17~6.04)	
HSPF2-4	(Btu/W)	10.3	
HSPF2-5	(Btu/W)	7.8	
COP	W/W	3.09	
Heat at 17F (H32)	(Btu/h)	9000	
Heat at 5F (H42)	(Btu/h)	10000	
COP at 5F (H42)	W/W	1.80	
Temperature Ratings:			
Indoor (cooling)	(Deg. °F)	62~90	
Indoor (heating)	(Deg. °F)	32~86	
Outdoor (cooling)	(Deg. °F)	-22~122	
Outdoor (heating)	(Deg. °F)	-22~75	

INDOOR UNIT DATA		
Input	(W)	45.00
Output	(W)	46.0
RLA	(A)	0.00
Speed(Hi/Mi/Lo)	(RPM)	600/520/460
Air Flow & Sound Data:		
Indoor air flow (Hi/Med/Lo)	(CFM)	352.94 / 305.88 / 270.59
Indoor noise level (Hi/Med/Lo)	(DBA)	39.5 / 36 / 32.5
Dry Mode (Dehumidification)	(LPH)	1.03

OUTDOOR UNIT DATA		
Compressor:		
Type		ROTARY
Capacity	(Btu/h)	11823
Input	(W)	885
Rated current (RLA)	(A)	8.8
Outdoor Fan Motor:		
Qty		1
Input	(W)	/
Output	(W)	34.00
RLA	(A)	0.42
Speed	(RPM)	850 / 680 / 450
Airflow & Sound Data:		
Outdoor air flow (Max.)	(CFM)	1323.5
Outdoor noise level	(DBA)	55.0

REFRIGERANT PIPE DATA		
Refrigerant type		R410A
Refrigerant charge	(oz)	41.62
Design pressure	(PSIG)	550/340
Liquid side / Gas side	(inch)	1/4" / 3/8"
Max. pipe length	(ft)	82.0
Max. height difference	(ft)	32.8
Refrigerant Precharge	(ft)	25.0
Additional charge for each ft	(oz/ft)	0.16
Connection method		Flared
Refrigerant oil / oil charge	(ml)	VG74/350

Dimensions:		
Indoor:		
Dimension (WxDxH)	(inch)	22.44 x 22.44 x 10.24
Packing(WxDxH)	(inch)	26.06 x 26.06 x 12.48
Net/Gross weight	(lbs.)	31.97 / 38.14
Outdoor:		
Dimension (WxDxH)	(inch)	31.69 x 12.99 x 21.81
Packing(WxDxH)	(inch)	36.02 x 14.57 x 24.21
Net/Gross weight	(lbs.)	74.07 / 80.25

WARRANTY	
	5 years compressor 5 years parts

Outdoor Unit Dimension

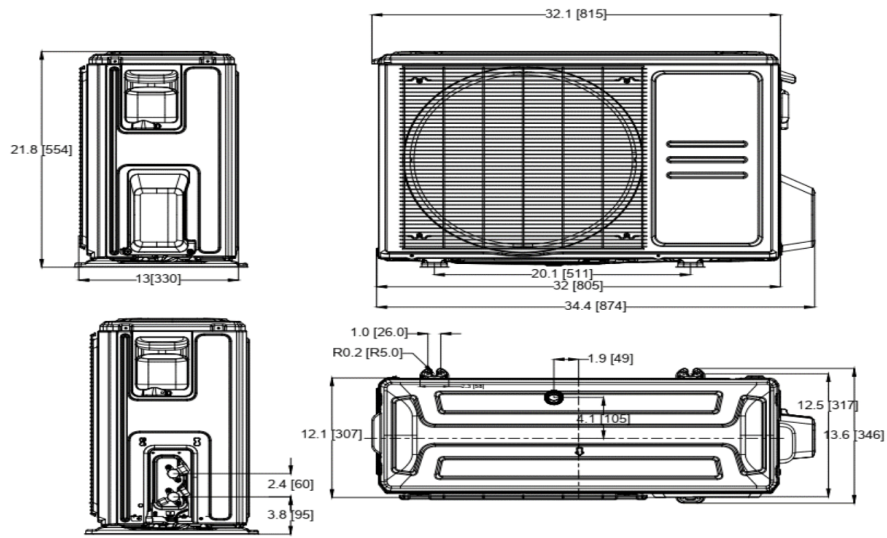

Indoor Unit Dimension

