

## Mitsutomo Submittal Data Sheet

### R-454B 9k Non High Heat Wall Mount Pump System

Job Name: \_\_\_\_\_

Engineer: \_\_\_\_\_

Submitted By: \_\_\_\_\_

Date: \_\_\_\_\_

Unit Tag: \_\_\_\_\_

#### System Info & Features:

- Large display handheld remote
- 24 hr timer
- Error code diagnosis
- Functions settings (see manual)
- Economy mode
- Turbo mode
- Dry mode



MODEL NUMBER	
Indoor unit:	RW-SZ09-LA-Q
Outdoor unit:	RO-SZ09-LA-Q
Certified:	

OPTIONAL ACCESSORIES	
Wifi Adapter	17310900A02901
7 Day Programmable Wall Thermostat	17317100A37597
3rd Party Thermostat Interface Adapter	17222000A68532

SYSTEM PERFORMANCE AND DATA	
<b>Cooling Efficiencies and Performance</b>	
SEER2	21.6
EER2	12.6
Rated Capacity	9000
Min/Max Capacity	2900~10500
Moisture Removal (L/H)	0.9
Standard Operating Range (F°)	5~122
Conditions:	Indoor: 80F° DB/67F° WB Outdoor: 95F° DB/75F° WB
<b>Heating Efficiencies and Performance</b>	
HSPF2-4	9.4
COP	3.27
1. @ 47F° Rated	10000
1. @ 47F° Min/Max Capacity	2400~11200
2. @ 17F° Rated	6600
3. @ 5F° Rated: Capacity / COP	7000/2.00
3. @ 5F° Max: Capacity	7000
Standard Operating Range (F°)	5~75
1. Conditions:	Indoor: 70F° DB/60F° WB Outdoor: 47F° DB/43F° WB
2. Conditions:	Indoor: 70F° DB/60F° WB Outdoor: 17F° DB/15F° WB
3. Conditions:	Indoor: 70F° DB/60F° WB Outdoor: 5F° DB/5F° WB

SPECIFICATIONS	
<b>Indoor:</b>	
Indoor Air Flow (Turbo/H/M/L/Q) (CFM)	306.1 / 247.2 / 176.6 / 141.3 / 141.3
Indoor Noise Level (Turbo/H/M/L/Q) (DBA)	43.0/38.5/33.0/24.0/19.5
<b>Heating Efficiencies and Performance</b>	
Compressor Type	ROTARY
Refrigerant	R454B
Refrigerant Oil Charge (OZ)	10.48
Refrigerant Oil	VG74
Outdoor Air Flow (Max) (CFM)	1294.1
Outdoor Noise Level (DBA)	53.5

ELECTRICAL	
Power Supply	208/230V,60Hz,1Ph
System Min. Circuit Amps	12.0
Connection Wiring	14/4
System Max Over Current Protection (A)	15
Compressor (RLA)	7.0
Outdoor Fan Motor (RLA)	0.3
Outdoor Fan Motor (W)	34
Indoor Fan Motor (RLA)	0.3
Indoor Fan Motor (W)	20
System Power Input @ Cooling (W)	714(300 ~ 880)
System Power Input @ Heating (W)	896(320 ~1100)

DIMENSIONS	
<b>Indoor:</b>	
Dimension (W×D×H)	28.70 x 7.87 x 11.50
Package (W×D×H)	31.10 x 10.63 x 14.76
Unit Weight (lbs)	18.08
Shipping Weight (lbs)	23.15
<b>Outdoor:</b>	
Dimension (W×D×H)	30.12 x 11.93 x 21.85
Package (W×D×H)	34.92 x 13.27 x 24.02
Unit Weight (lbs)	54.23
Shipping Weight (lbs)	59.74

REFRIGERANT PIPE DATA	
Liquid Size (in.)	1/4
Gas Size (in.)	3/8
Max. Piping Length (ft)	82.00
Max. Height Difference (ft)	49.20
Max. Pre-charged Length (ft)	24.6
Refrigerant Pre-charged Amount (oz)	21.52
Additional Charge of Refrigerant (oz/ft)	0.16
Connection Method	Flared

WARRANTY	
	5 years compressor 5 years parts

## Outdoor Unit Dimension

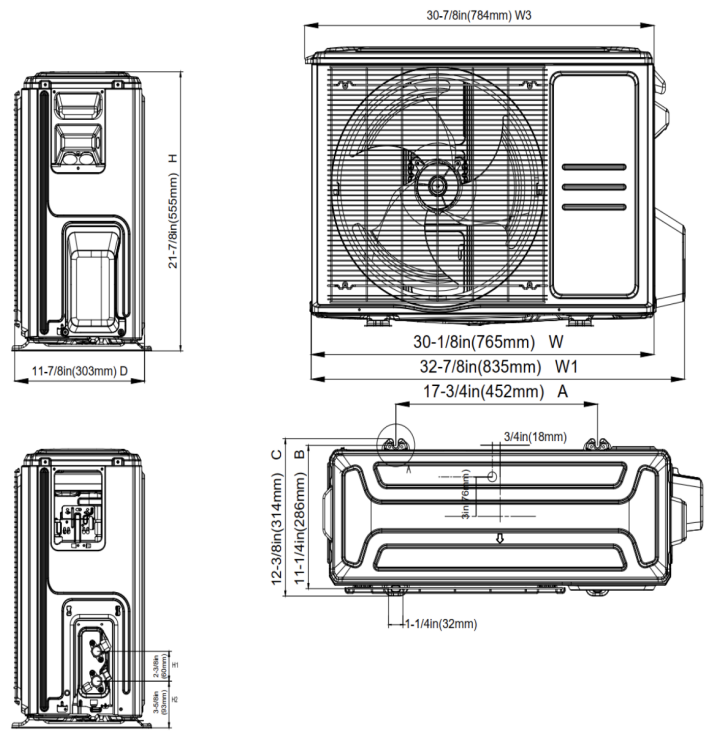

## Indoor Unit Dimension (Internal Pump)

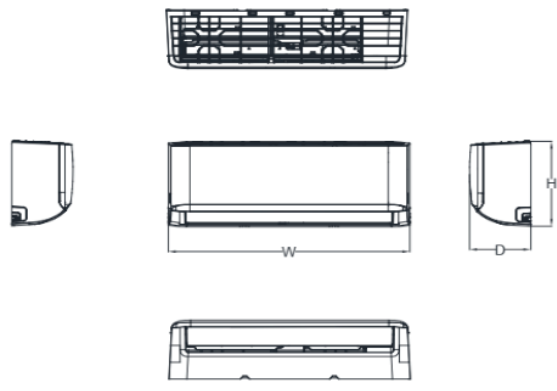

Capacity	W	D	H
9k	28.70	7.87	11.50