

Mitsutomo Submittal Data Sheet

R-454B 24K High Heat 4-Way Cassette Heat Pump System

Job Name: _____
Engineer: _____
Submitted By: _____

Date: _____
Unit Tag: _____

System Info & Features:

- Handled Remote
 - 4 Way Multi Directional
 - Heating Down to -22 deg
 - Turbo Mode
 - Dry mode
- Self Diagnostics
 - Super Quiet
 - Built in Condensate Pump
 - 7 Day Programmable Wall Thermostat



MODEL NUMBER	
Indoor unit:	HC-UZ24-LA-Q
Outdoor unit:	HO-SZ24-LA-Q
Certified:	

OPTIONAL ACCESSORIES	
Wifi Adapter	17310900A02901
3rd Party Thermostat Interface Adapter	17222000A68532

SYSTEM PERFORMANCE AND DATA	
Cooling Efficiencies and Performance	
SEER2	20.7
EER2	12.0
Rated Capacity	23400
Min/Max Capacity	12800~26200
Moisture Removal (L/H)	2.36
Standard Operating Range (F°)	-22~-122
Conditions:	Indoor: 80F° DB/67F° WB Outdoor: 95F° DB/75F° WB
Heating Efficiencies and Performance	
HSPF2-4	11.6
COP	3.54
1. @ 47F° Rated	25000
1. @ 47F° Min/Max Capacity	11500~30700
2. @ 17F° Rated	20400
3. @ 5F° Rated: Capacity / COP	23800/2.23
3. @ 5F° Max: Capacity	23800
Standard Operating Range (F°)	-22~-75
1. Conditions:	Indoor: 70F° DB/60F° WB Outdoor: 47F° DB/43F° WB
2. Conditions:	Indoor: 70F° DB/60F° WB Outdoor: 17F° DB/15F° WB
3. Conditions:	Indoor: 70F° DB/60F° WB Outdoor: 5F° DB/5F° WB

SPECIFICATIONS	
Indoor:	
Indoor Air Flow (Turbo/H/M/L/Q)	(CFM) 765.2 / 706.3 / 635.7 / 547.4 / 547.4
Indoor Noise Level (Turbo/H/M/L/Q)	(DBA) 48.5 / 45 / 42.5 / 33.5 / 33.5
Heating Efficiencies and Performance	
Compressor Type	ROTARY
Refrigerant	R454B
Refrigerant Oil Charge (OZ)	20.96
Refrigerant Oil	VG74
Outdoor Air Flow (Max)	(CFM) 2236.7
Outdoor Noise Level	(DBA) 61.5

ELECTRICAL	
Power Supply	208/230V,60Hz,1Ph
System Min. Circuit Amps	24.90
Connection Wiring	14/4
System Max Over Current Protection (A)	25
Compressor (RLA)	15.0
Outdoor Fan Motor (RLA)	1.3
Outdoor Fan Motor (W)	120
Indoor Fan Motor (RLA)	1.0
Indoor Fan Motor (W)	45
System Power Input @ Cooling (W)	1950(960 ~ 2300)
System Power Input @ Heating (W)	2070(695 ~2490)

DIMENSIONS		
Indoor:		
Dimension	(W×D×H)	32.68 x 32.68 x 8.07
Package	(W×D×H)	35.83 x 35.83 x 9.84
Unit Weight	(lbs)	47.18
Shipping Weight	(lbs)	59.08
Outdoor:		
Dimension	(W×D×H)	37.24 x 16.14 x 31.89
Package	(W×D×H)	42.91 x 19.68 x 34.84
Unit Weight	(lbs)	130.29
Shipping Weight	(lbs)	141.31

REFRIGERANT PIPE DATA		
Liquid Size	(in.)	3/8
Gas Size	(in.)	5/8
Max. Piping Length	(ft)	164.00
Max. Height Difference	(ft)	82.00
Max. Pre-charged Length	(ft)	24.6
Refrigerant Pre-charged Amount	(oz)	63.49
Additional Charge of Refrigerant	(oz/ft)	0.32
Connection Method		Flared

WARRANTY	
	5 years compressor 5 years parts

Outdoor Unit Dimension

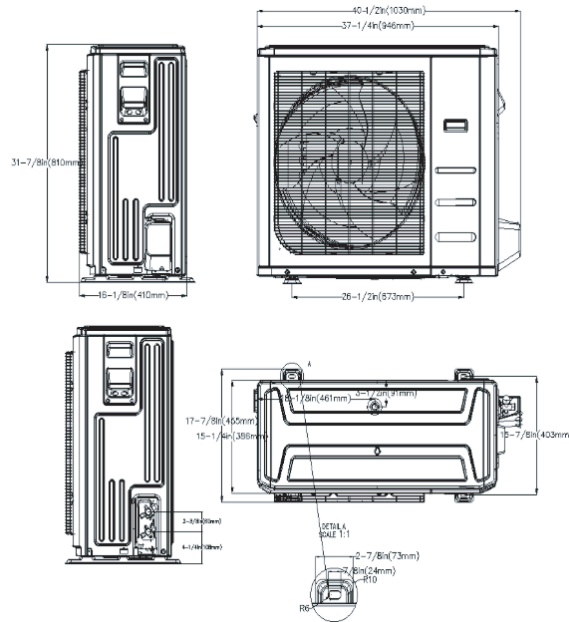

Indoor Unit Dimension (Internal Pump)

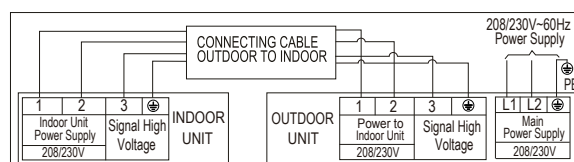
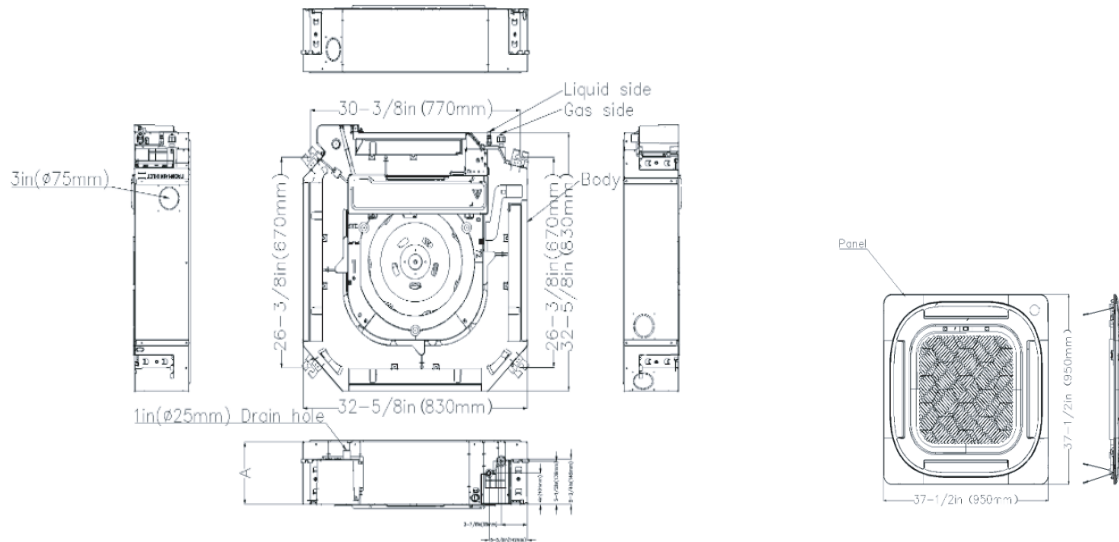

Connection Diagram