

Mitsutomo Submittal Data Sheet

R-454B 30k Non High Heat Wall Mount Pump System

Job Name: _____
Engineer: _____
Submitted By: _____

Date: _____
Unit Tag: _____

System Info & Features:

- Large display handheld remote
- Economy mode
- 24 hr timer
- Turbo mode
- Error code diagnosis
- Dry mode
- Functions settings (see manual)



MODEL NUMBER	
Indoor unit:	HW-UZ30-LA-Q
Outdoor unit:	RU-UZ30-LA-Q
Certified:	

OPTIONAL ACCESSORIES	
Wifi Adapter	17310900A02901
7 Day Programmable Wall Thermostat	17317100A37597
3rd Party Thermostat Interface Adapter	17222000A68532

SYSTEM PERFORMANCE AND DATA	
Cooling Efficiencies and Performance	
SEER2	22.3
EER2	12.0
Rated Capacity	30000
Min/Max Capacity	6800~33900
Moisture Removal (L/H)	3.6
Standard Operating Range (F°)	-13~122
Conditions:	Indoor: 80F° DB/67F° WB Outdoor: 95F° DB/75F° WB
Heating Efficiencies and Performance	
HSPF2-4	9.0
COP	3.03
1. @ 47F° Rated	30000
1. @ 47F° Min/Max Capacity	12300~32100
2. @ 17F° Rated	20000
3. @ 5F° Rated: Capacity / COP	20000/1.94
3. @ 5F° Max: Capacity	20000
Standard Operating Range (F°)	-13~75
1. Conditions:	Indoor: 70F° DB/60F° WB Outdoor: 47F° DB/43F° WB
2. Conditions:	Indoor: 70F° DB/60F° WB Outdoor: 17F° DB/15F° WB
3. Conditions:	Indoor: 70F° DB/60F° WB Outdoor: 5F° DB/5F° WB

SPECIFICATIONS	
Indoor:	
Indoor Air Flow (Turbo/H/M/L/Q) (CFM)	871.1 / 647.5 / 447.3 / 329.6 / 329.6
Indoor Noise Level (Turbo/H/M/L/Q) (DBA)	56.5 / 52 / 45 / 36 / 22
Heating Efficiencies and Performance	
Compressor Type	ROTARY
Refrigerant	R454B
Refrigerant Oil Charge (OZ)	22.66
Refrigerant Oil	VG74
Outdoor Air Flow (Max) (CFM)	2235.3
Outdoor Noise Level (DBA)	61.5

DIMENSIONS	
Indoor:	
Dimension (W×D×H)	49.57 x 11.14 x 14.25
Package (W×D×H)	52.76 x 17.72 x 15.16
Unit Weight (lbs)	43.43
Shipping Weight (lbs)	56.88
Outdoor:	
Dimension (W×D×H)	37.24 x 16.14 x 31.89
Package (W×D×H)	42.91 x 19.68 x 34.84
Unit Weight (lbs)	142.86
Shipping Weight (lbs)	154.54

ELECTRICAL	
Power Supply	208/230V,60Hz,1Ph
System Min. Circuit Amps	28.0
Connection Wiring	14/4
System Max Over Current Protection (A)	30
Compressor (RLA)	17.5
Outdoor Fan Motor (RLA)	1.3
Outdoor Fan Motor (W)	120
Indoor Fan Motor (RLA)	0.7
Indoor Fan Motor (W)	58
System Power Input @ Cooling (W)	2500(700 ~ 3220)
System Power Input @ Heating (W)	2900(755 ~ 2950)

REFRIGERANT PIPE DATA	
Liquid Size (in.)	3/8
Gas Size (in.)	5/8
Max. Piping Length (ft)	164.00
Max. Height Difference (ft)	82.0
Max. Pre-charged Length (ft)	24.6
Refrigerant Pre-charged Amount (oz)	84.66
Additional Charge of Refrigerant (oz/ft)	0.32
Connection Method	Flared

WARRANTY	
	5 years compressor 5 years parts

Outdoor Unit Dimension

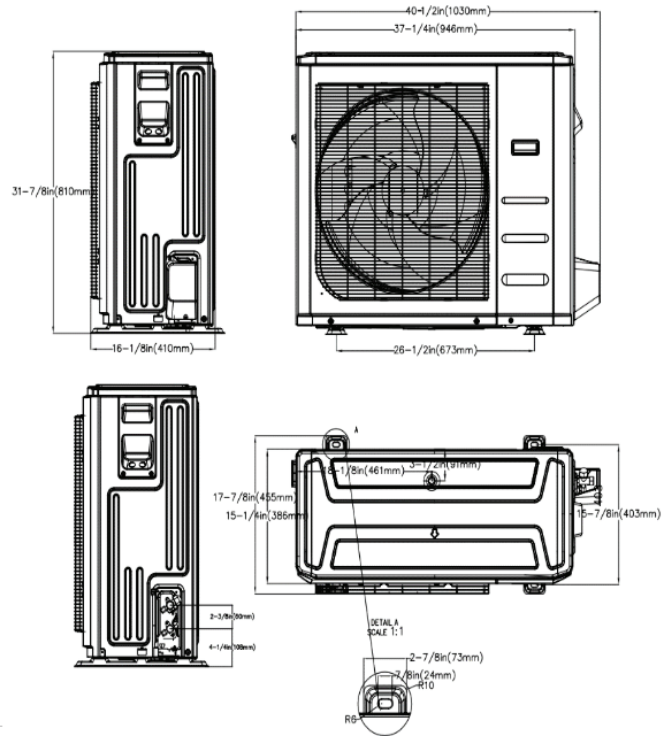

Indoor Unit Dimension (Internal Pump)

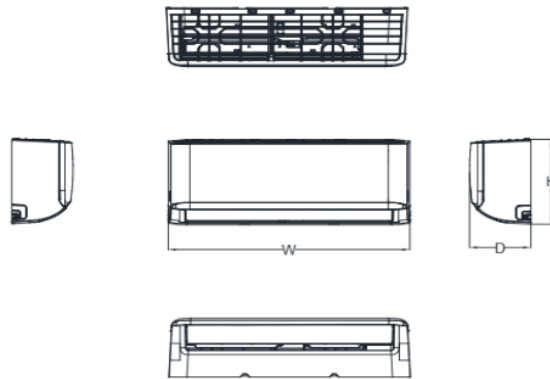

Capacity	W	D	H
30k	49.57	11.14	14.25