

## Mitsutomo Submittal Data Sheet

### R-454B 33k High Heat Single Zone Wall Mount Pump System

Job Name: \_\_\_\_\_

Engineer: \_\_\_\_\_

Submitted By: \_\_\_\_\_

Date: \_\_\_\_\_

Unit Tag: \_\_\_\_\_

#### System Info & Features:

- Large display handheld remote
  - 24 hr timer
  - Error code diagnosis
  - Functions settings (see manual)
- Economy mode
  - Turbo mode
  - Dry mode



MODEL NUMBER	
Indoor unit:	HW-UZ33-LA-Q
Outdoor unit:	HO-SZ33-LA-Q
Certified:	

OPTIONAL ACCESSORIES	
Wifi Adapter	17310900A02901
7 Day Programmable Wall Thermostat	17317100A37597
3rd Party Thermostat Interface Adapter	17222000A68532

SYSTEM PERFORMANCE AND DATA	
<b>Cooling Efficiencies and Performance</b>	
SEER2	20.0
EER2	11.7
Rated Capacity	33000
Min/Max Capacity	15000~35900
Moisture Removal (L/H)	4.5
Standard Operating Range (F°)	-22~122
Conditions:	Indoor: 80F° DB/67F° WB Outdoor: 95F° DB/75F° WB
<b>Heating Efficiencies and Performance</b>	
HSPF2-4	10.5
COP	3.22
1. @ 47F° Rated	36000
1. @ 47F° Min/Max Capacity	19900~38200
2. @ 17F° Rated	29600
3. @ 5F° Rated: Capacity / COP	34600/1.91
3. @ 5F° Max: Capacity	34600
Standard Operating Range (F°)	-22~75
1. Conditions:	Indoor: 70F° DB/60F° WB Outdoor: 47F° DB/43F° WB
2. Conditions:	Indoor: 70F° DB/60F° WB Outdoor: 17F° DB/15F° WB
3. Conditions:	Indoor: 70F° DB/60F° WB Outdoor: 5F° DB/5F° WB

SPECIFICATIONS	
<b>Indoor:</b>	
Indoor Air Flow (Turbo/H/M/L/Q) (CFM)	829.9 / 676.9 / 529.7 / 447.3 / 447.3
Indoor Noise Level (Turbo/H/M/L/Q) (DBA)	56.0 / 52.5 / 46.5 / 29.5 / 23.0
<b>Heating Efficiencies and Performance</b>	
Compressor Type	TWIN-ROTARY
Refrigerant	R454B
Refrigerant Oil Charge (OZ)	33.81
Refrigerant Oil	VG74
Outdoor Air Flow (Max) (CFM)	2235.3
Outdoor Noise Level (DBA)	63.5

ELECTRICAL	
Power Supply	208/230V,60Hz,1Ph
System Min. Circuit Amps	34.0
Connection Wiring	14/4
System Max Over Current Protection (A)	35
Compressor (RLA)	24.5
Outdoor Fan Motor (RLA)	1.5
Outdoor Fan Motor (W)	230
Indoor Fan Motor (RLA)	1.6
Indoor Fan Motor (W)	58
System Power Input @ Cooling (W)	2821(440 ~ 3450)
System Power Input @ Heating (W)	3277(1245 ~ 4120)

DIMENSIONS	
<b>Indoor:</b>	
Dimension (W×D×H)	49.57 x 11.14 x 14.25
Package (W×D×H)	52.76 x 17.72 x 15.16
Unit Weight (lbs)	43.21
Shipping Weight (lbs)	57.32
<b>Outdoor:</b>	
Dimension (W×D×H)	37.24 x 16.14 x 31.89
Package (W×D×H)	42.91 x 19.68 x 34.84
Unit Weight (lbs)	156.97
Shipping Weight (lbs)	167.99

REFRIGERANT PIPE DATA	
Liquid Size (in.)	3/8
Gas Size (in.)	3/4
Max. Piping Length (ft)	164.0
Max. Height Difference (ft)	82.0
Max. Pre-charged Length (ft)	24.6
Refrigerant Pre-charged Amount (oz)	87.13
Additional Charge of Refrigerant (oz/ft)	0.32
Connection Method	Flared

WARRANTY	
	5 years compressor 5 years parts

## Outdoor Unit Dimension

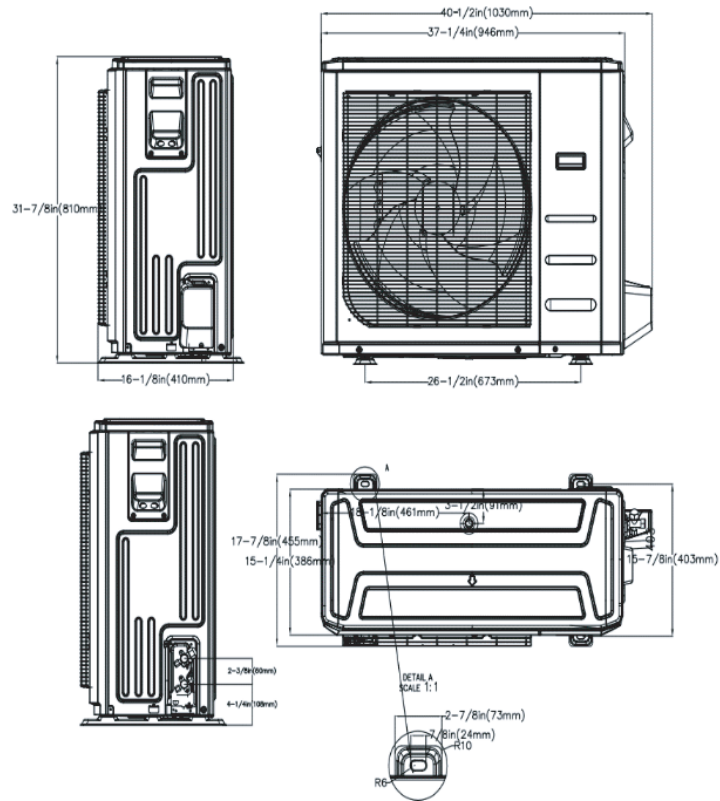

## Indoor Unit Dimension (Internal Pump)

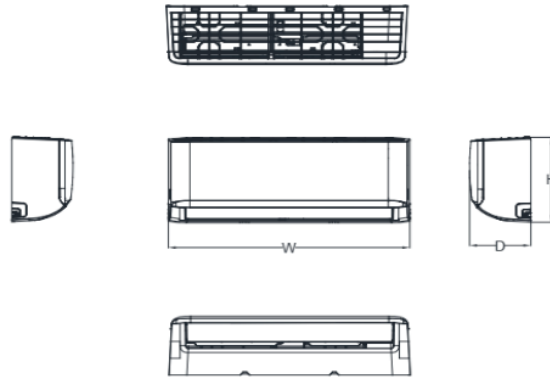

Capacity	W	D	H
33k	49.57	11.14	14.25