

Mitsutomo Submittal Data Sheet

R-454B 36K High Heat 4-Way Cassette Heat Pump System

Job Name: _____

Engineer: _____

Submitted By: _____

Date: _____

Unit Tag: _____

System Info & Features:

- Handled Remote
- 4 Way Multi Directional
- Heating Down to -22 deg
- Turbo Mode
- Dry mode
- Self Diagnostics
- Super Quiet
- Built in Condensate Pump
- 7 Day Programmable Wall Thermostat



MODEL NUMBER	
Indoor unit:	HC-UG36-LA-Q
Outdoor unit:	HO-SG36-LA-Q
Certified:	

OPTIONAL ACCESSORIES	
Wifi Adapter	17310900A02901
3rd Party Thermostat Interface Adapter	17222000A68532

SYSTEM PERFORMANCE AND DATA	
Cooling Efficiencies and Performance	
SEER2	21.2
EER2	12.0
Rated Capacity	36600
Min/Max Capacity	4900~38000
Moisture Removal (L/H)	4.30
Standard Operating Range (F°)	-22~-122
Conditions:	Indoor: 80F° DB/67F° WB Outdoor: 95F° DB/75F° WB
Heating Efficiencies and Performance	
HSPF2-4	10.6
COP	3.43
1. @ 47F° Rated	37000
1. @ 47F° Min/Max Capacity	11400~44600
2. @ 17F° Rated	30600
3. @ 5F° Rated: Capacity / COP	37000/1.95
3. @ 5F° Max: Capacity	37000
Standard Operating Range (F°)	-22~-75
1. Conditions:	Indoor: 70F° DB/60F° WB Outdoor: 47F° DB/43F° WB
2. Conditions:	Indoor: 70F° DB/60F° WB Outdoor: 17F° DB/15F° WB
3. Conditions:	Indoor: 70F° DB/60F° WB Outdoor: 5F° DB/5F° WB

SPECIFICATIONS	
Indoor:	
Indoor Air Flow (Turbo/H/M/L/Q) (CFM)	1041.8 / 947.6 / 853.5 / 753.4 / 659.2
Indoor Noise Level (Turbo/H/M/L/Q) (DBA)	52 / 52 / 47.5 / 40 / 38
Heating Efficiencies and Performance	
Compressor Type	TWIN-ROTARY
Refrigerant	R454B
Refrigerant Oil Charge (OZ)	49.37
Refrigerant Oil	VG75
Outdoor Air Flow (Max) (CFM)	3001.9
Outdoor Noise Level (DBA)	64.5

ELECTRICAL	
Power Supply	208/230V,60Hz,1Ph
System Min. Circuit Amps	38.00
Connection Wiring	Power: 14/3 Communication: 18/2 Stranded
System Max Over Current Protection (A)	40
Compressor (RLA)	24.5
Outdoor Fan Motor (RLA)	2.1
Outdoor Fan Motor (W)	250
Indoor Fan Motor (RLA)	1.0
Indoor Fan Motor (W)	125
System Power Input @ Cooling (W)	3042(580 ~ 3480)
System Power Input @ Heating (W)	3161(740 ~4160)

DIMENSIONS	
Indoor:	
Dimension (W×D×H)	32.68 x 32.68 x 9.65
Package (W×D×H)	35.83 x 35.83 x 11.42
Unit Weight (lbs)	59.30
Shipping Weight (lbs)	71.43
Outdoor:	
Dimension (W×D×H)	38.58 x 16.34 x 38.39
Package (W×D×H)	45.08 x 19.68 x 42.52
Unit Weight (lbs)	206.57
Shipping Weight (lbs)	237.44

REFRIGERANT PIPE DATA	
Liquid Size (in.)	3/8
Gas Size (in.)	3/4
Max. Piping Length (ft)	246.00
Max. Height Differencex (ft)	98.40
Max. Pre-charged Length (ft)	24.6
Refrigerant Pre-charged Amount (oz)	126.99
Additional Charge of Refrigerant (oz/ft)	0.32
Connection Method	Flared

WARRANTY	
	5 years compressor 5 years parts

Outdoor Unit Dimension

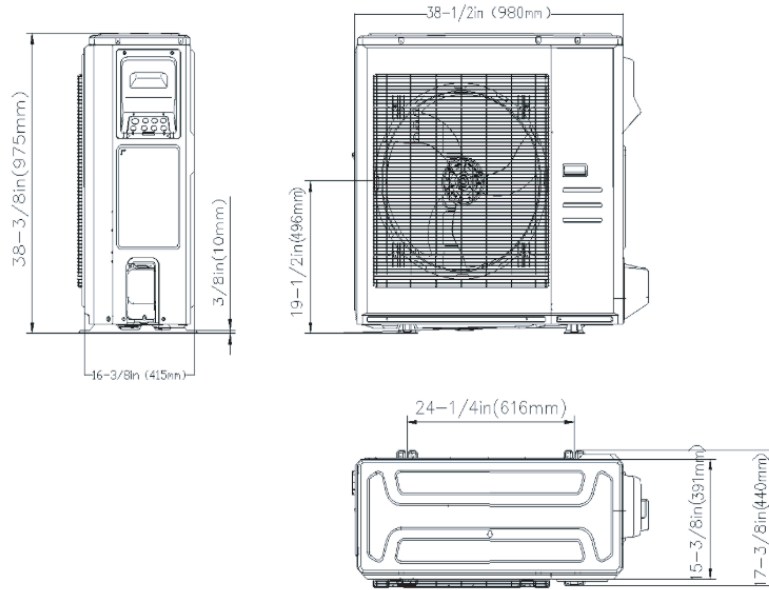

Indoor Unit Dimension (Internal Pump)

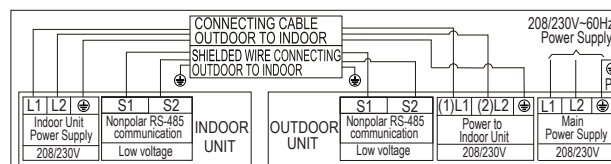
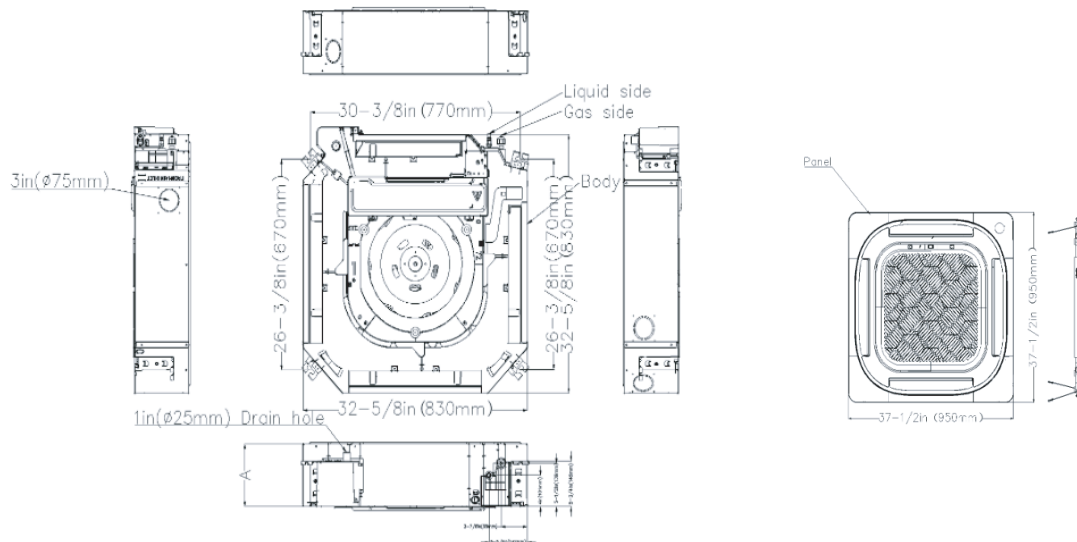

Connection Diagram