

## Mitsutomo Submittal Data Sheet

### R-454B 36k High Heat Slim Ducted Heat Pump

Job Name: \_\_\_\_\_

Engineer: \_\_\_\_\_

Submitted By: \_\_\_\_\_

Date: \_\_\_\_\_

Unit Tag: \_\_\_\_\_

#### System Info & Features:

- Slim design
- Up to .8" Static Pressure
- Heating down to -22 deg
- Self diagnostics
- Super quiet
- 7 Day Programmable Wall Thermostat



MODEL NUMBER	
Indoor unit:	HD-UG36-LA-Q
Outdoor unit:	HO-SG36-LA-Q
Certified:	

OPTIONAL ACCESSORIES	
3rd Party Thermostat Interface Adapter	17222000A68532

SYSTEM PERFORMANCE AND DATA	
<b>Cooling Efficiencies and Performance</b>	
SEER2	17.7
EER2	12.0
Rated Capacity	36000
Min/Max Capacity	9800~37000
Moisture Removal (L/H)	3.00
Standard Operating Range (F°)	-22~-122
Conditions:	Indoor: 80F° DB/67F° WB Outdoor: 95F° DB/75F° WB
<b>Heating Efficiencies and Performance</b>	
HSPF2-4	11.1
COP	3.80
1. @ 47F° Rated	42000
1. @ 47F° Min/Max Capacity	11000~45500
2. @ 17F° Rated	31600
3. @ 5F° Rated: Capacity / COP	37600/2.10
3. @ 5F° Max: Capacity	37600
Standard Operating Range (F°)	-22~-75
1. Conditions:	Indoor: 70F° DB/60F° WB Outdoor: 47F° DB/43F° WB
2. Conditions:	Indoor: 70F° DB/60F° WB Outdoor: 17F° DB/15F° WB
3. Conditions:	Indoor: 70F° DB/60F° WB Outdoor: 5F° DB/5F° WB

SPECIFICATIONS	
<b>Indoor:</b>	
Indoor Air Flow (Turbo/H/M/L/Q) (CFM)	1236.1 / 1059.5 / 941.8 / 765.2 / 765.2
Indoor Noise Level (Turbo/H/M/L/Q) (DBA)	45 / 45 / 40 / 34 / 31
<b>Heating Efficiencies and Performance</b>	
Compressor Type	TWIN-ROTARY
Refrigerant	R454B
Refrigerant Oil Charge (OZ)	49.37
Refrigerant Oil	VC75
Outdoor Air Flow (Max) (CFM)	3001.9
Outdoor Noise Level (DBA)	65.0

ELECTRICAL	
Power Supply	208/230V,60Hz,1Ph
System Min. Circuit Amps	38.00
Connection Wiring	Power: 14/3 Communication: 18/2 Stranded
System Max Over Current Protection (A)	40
Compressor (RLA)	24.5
Outdoor Fan Motor (RLA)	2.1
Outdoor Fan Motor (W)	250
Indoor Fan Motor (RLA)	3.2
Indoor Fan Motor (W)	400
System Power Input @ Cooling (W)	3000(900 ~ 3680)
System Power Input @ Heating (W)	3240(680 ~ 3850)

DIMENSIONS	
<b>Indoor:</b>	
Dimension (W×D×H)	47.24 x 29.53 x 11.81
Package (W×D×H)	56.10 x 33.86 x 14.13
Unit Weight (lbs)	106.26
Shipping Weight (lbs)	120.37
<b>Outdoor:</b>	
Dimension (W×D×H)	38.58 x 16.34 x 38.39
Package (W×D×H)	45.08 x 19.68 x 42.52
Unit Weight (lbs)	206.57
Shipping Weight (lbs)	237.44

REFRIGERANT PIPE DATA	
Liquid Size (in.)	3/8
Gas Size (in.)	3/4
Max. Piping Length (ft)	246.00
Max. Height Differencex (ft)	98.40
Max. Pre-charged Length (ft)	24.6
Refrigerant Pre-charged Amount (oz)	126.99
Additional Charge of Refrigerant (oz/ft)	0.32
Connection Method	Flared

WARRANTY	
	5 years compressor 5 years parts

## Outdoor Unit Dimension

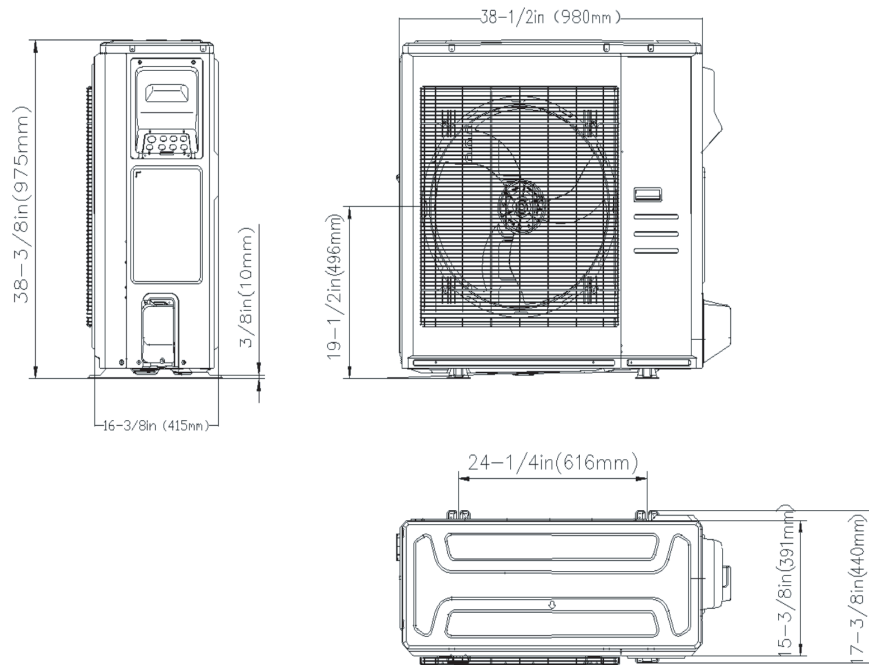

## Indoor Unit Dimension (Internal Pump)

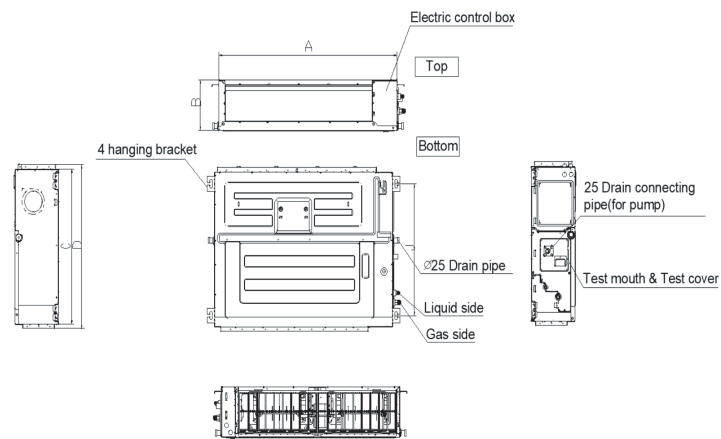

Capacity	W	D	H
36k	47.24	29.53	11.81