

Mitsutomo Submittal Data Sheet

R-454B 9K High Heat 1-Way Cassette Heat Pump System

Job Name: _____

Engineer: _____

Submitted By: _____

Date: _____

Unit Tag: _____

System Info & Features:

- One way ceiling cassette heat pumps
- Fits between most ceiling joists
- Large display and handheld remote
 - 24 hour timer
 - Error code diagnosis
 - Functions settings (see manual)
- 7-Day Programmable wall mount wifi thermostat with infrared
- Economy mode
- Turbo mode
- Dry mode
- Heating down to -22 degrees
- Drop down filter

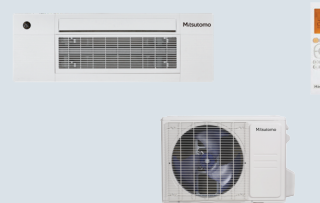

MODEL NUMBER	
Indoor unit:	HO-SZ09-LA-Q
Outdoor unit:	HJ-UZ09-LA-Q
Certified:	

OPTIONAL ACCESSORIES	
Wifi Adapter	17310900A02901
3rd Party Thermostat Interface Adapter	17222000A68532

SYSTEM PERFORMANCE AND DATA	
Cooling Efficiencies and Performance	
SEER2	24.0
EER2	14.6
Rated Capacity	9000
Min/Max Capacity	4000-12900
Moisture Removal (L/H)	0.98
Standard Operating Range (F°)	-22~-122
Conditions:	Indoor: 80F° DB/67F° WB Outdoor: 95F° DB/75F° WB
Heating Efficiencies and Performance	
HSPF2-4	12.1
COP	3.71
1. @ 47F° Rated	10900
1. @ 47F° Min/Max Capacity	3800-13900
2. @ 17F° Rated	9000
3. @ 5F° Rated: Capacity / COP	10600/1.83
3. @ 5F° Max: Capacity	10600
Standard Operating Range (F°)	-22~75
1. Conditions:	Indoor: 70F° DB/60F° WB Outdoor: 47F° DB/43F° WB
2. Conditions:	Indoor: 70F° DB/60F° WB Outdoor: 17F° DB/15F° WB
3. Conditions:	Indoor: 70F° DB/60F° WB Outdoor: 5F° DB/5F° WB

SPECIFICATIONS	
Indoor:	
Indoor Air Flow (Turbo/H/M/L/Q) (CFM)	341.4 / 294.3 / 259.0 / 235.4 / 235.4
Indoor Noise Level (Turbo/H/M/L/Q) (DBA)	38 / 38 / 36 / 33 / 24
Heating Efficiencies and Performance	
Compressor Type	ROTARY
Refrigerant	R454B
Refrigerant Oil Charge (OZ)	11.83
Refrigerant Oil	VG74
Outdoor Air Flow (Max) (CFM)	1471.5
Outdoor Noise Level (DBA)	54.5

ELECTRICAL	
Power Supply	208/230V,60Hz,1Ph
System Min. Circuit Amps	15.00
Connection Wiring	14/4
System Max Over Current Protection (A)	15
Compressor (RLA)	10.4
Outdoor Fan Motor (RLA)	0.6
Outdoor Fan Motor (W)	34
Indoor Fan Motor (RLA)	0.8
Indoor Fan Motor (W)	30
System Power Input @ Cooling (W)	610(147 ~ 1150)
System Power Input @ Heating (W)	860(300 ~1350)

DIMENSIONS	
Indoor:	
Dimension (W×D×H)	50.31 x 13.19 x 8.98
Package (W×D×H)	57.60 x 22.48 x 22.64
Unit Weight (lbs)	45.19
Shipping Weight (lbs)	82.45
Outdoor:	
Dimension (W×D×H)	31.69 x 12.99 x 21.81
Package (W×D×H)	36.02 x 14.57 x 24.21
Unit Weight (lbs)	72.75
Shipping Weight (lbs)	78.70

REFRIGERANT PIPE DATA	
Liquid Size (in.)	1/4
Gas Size (in.)	3/8
Max. Piping Length (ft)	82.02
Max. Height Differencex (ft)	49.21
Max. Pre-charged Length (ft)	24.6
Refrigerant Pre-charged Amount (oz)	35.27
Additional Charge of Refrigerant (oz/ft)	0.16
Connection Method	Flared

WARRANTY	
	5 years compressor 5 years parts

Outdoor Unit Dimension

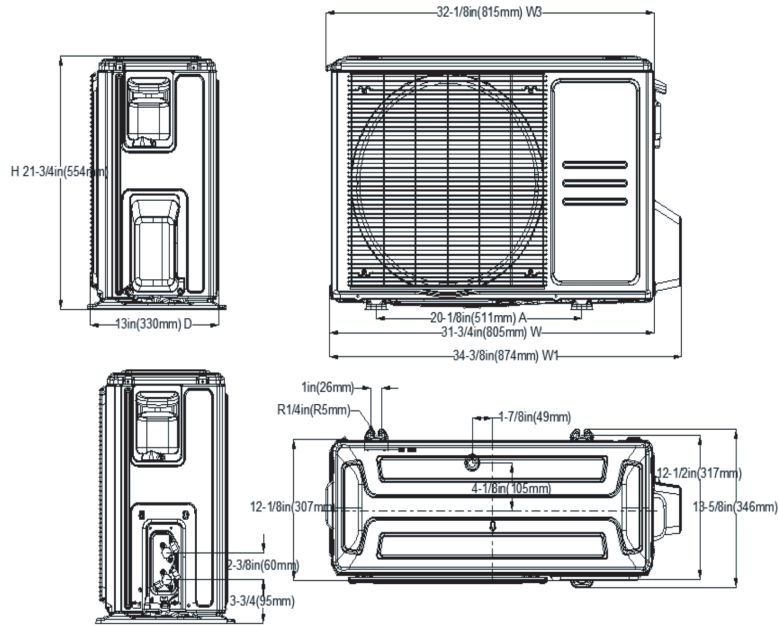

Indoor Unit Dimension (Internal Pump)

