

## Mitsutomo Submittal Data Sheet

### R-454B 9k High Heat Slim Ducted Heat Pump

Job Name: \_\_\_\_\_

Engineer: \_\_\_\_\_

Submitted By: \_\_\_\_\_

Date: \_\_\_\_\_

Unit Tag: \_\_\_\_\_

#### System Info & Features:

- Slim design
- Up to .8" Static Pressure
- Heating down to -22 deg
- Self diagnostics
- Super quiet
- 7 Day Programmable Wall Thermostat



MODEL NUMBER	
Indoor unit:	S-HD-UZ09-LA-Q
Outdoor unit:	HO-SZ09-LA-Q
Certified:	

OPTIONAL ACCESSORIES	
3rd Party Thermostat Interface Adapter	17222000A68532

SYSTEM PERFORMANCE AND DATA	
<b>Cooling Efficiencies and Performance</b>	
SEER2	20.5
EER2	14.0
Rated Capacity	9000
Min/Max Capacity	3000~13100
Moisture Removal (L/H)	0.69
Standard Operating Range (F°)	-22~-122
Conditions:	Indoor: 80F° DB/67F° WB Outdoor: 95F° DB/75F° WB
<b>Heating Efficiencies and Performance</b>	
HSPF2-4	13.8
COP	3.88
1. @ 47F° Rated	9900
1. @ 47F° Min/Max Capacity	3900~16500
2. @ 17F° Rated	10200
3. @ 5F° Rated: Capacity / COP	11900/1.85
3. @ 5F° Max: Capacity	11900
Standard Operating Range (F°)	-22~-75
1. Conditions:	Indoor: 70F° DB/60F° WB Outdoor: 47F° DB/43F° WB
2. Conditions:	Indoor: 70F° DB/60F° WB Outdoor: 17F° DB/15F° WB
3. Conditions:	Indoor: 70F° DB/60F° WB Outdoor: 5F° DB/5F° WB

SPECIFICATIONS	
<b>Indoor:</b>	
Indoor Air Flow (Turbo/H/M/L/Q) (CFM)	344.3 / 288.4 / 230.7 / 200.7 / 121.8
Indoor Noise Level (Turbo/H/M/L/Q) (DBA)	29.5 / 29.5 / 28.5 / 27.5 / 26
<b>Heating Efficiencies and Performance</b>	
Compressor Type	ROTARY
Refrigerant	R454B
Refrigerant Oil Charge (OZ)	11.83
Refrigerant Oil	VG74
Outdoor Air Flow (Max) (CFM)	1471.5
Outdoor Noise Level (DBA)	54.0

ELECTRICAL	
Power Supply	208/230V,60Hz,1Ph
System Min. Circuit Amps	15.00
Connection Wiring	14/4
System Max Over Current Protection (A)	15
Compressor (RLA)	10.4
Outdoor Fan Motor (RLA)	0.6
Outdoor Fan Motor (W)	34
Indoor Fan Motor (RLA)	1.5
Indoor Fan Motor (W)	165
System Power Input @ Cooling (W)	642(150 ~ 1260)
System Power Input @ Heating (W)	750(260 ~1420)

DIMENSIONS	
<b>Indoor:</b>	
Dimension (W×D×H)	27.56 x 29.53 x 9.65
Package (W×D×H)	36.42 x 33.46 x 11.73
Unit Weight (lbs)	64.15
Shipping Weight (lbs)	73.85
<b>Outdoor:</b>	
Dimension (W×D×H)	31.69 x 12.99 x 21.81
Package (W×D×H)	36.02 x 14.57 x 24.21
Unit Weight (lbs)	72.75
Shipping Weight (lbs)	78.70

REFRIGERANT PIPE DATA	
Liquid Size (in.)	1/4
Gas Size (in.)	3/8
Max. Piping Length (ft)	82.00
Max. Height Differencex (ft)	49.20
Max. Pre-charged Length (ft)	24.6
Refrigerant Pre-charged Amount (oz)	35.27
Additional Charge of Refrigerant (oz/ft)	0.16
Connection Method	Flared

WARRANTY	
	5 years compressor 5 years parts

## Outdoor Unit Dimension

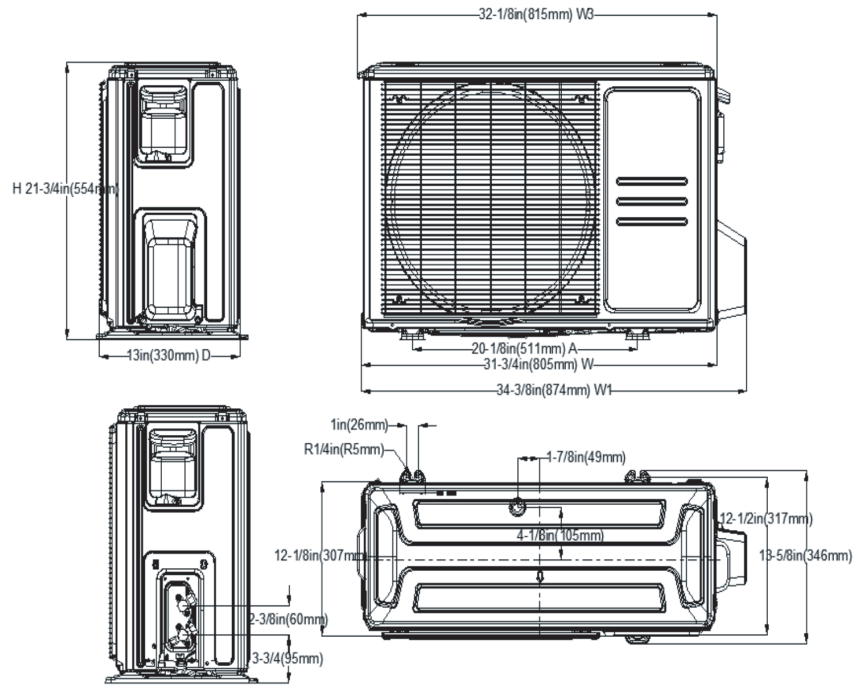

## Indoor Unit Dimension (Internal Pump)

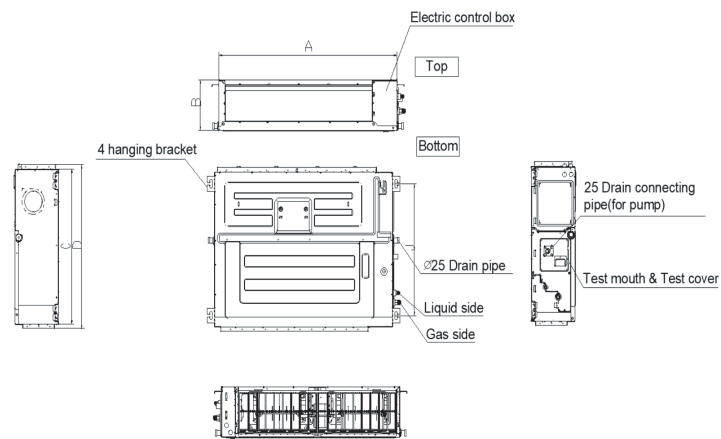

Capacity	W	D	H
9k	27.56	29.53	9.65