

Mitsutomo Submittal Data Sheet

R-454B 12K Slim Ducted Multi Zone Evap

Job Name: _____

Engineer: _____

Submitted By: _____

Date: _____

Unit Tag: _____

System Info & Features:

- Slim design
- Up to .8" Static Pressure
- Heating down to -22 deg
- Self diagnostics
- Super quiet
- 7 Day Programmable Wall Thermostat

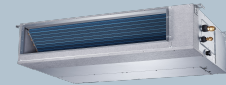

MODEL NUMBER

Indoor unit: S-HD-UZ12-LA-Q

Certified:    

SYSTEM PERFORMANCE DATA

Electrical:		
Normal Operational Voltage	(V, Ph, Hz)	208/230V,60Hz,1Ph
Connection wiring		14/4
Performance Data:		
Rated Capacity		12000
Min/Max Capacity		3000~13300
Moisture Removal	(L/H)	1.39

REFRIGERANT PIPE DATA

Refrigerant Type		R454B
Liquid Side	(inch)	1/4
Gas Side	(inch)	3/8
Connection Method		Flared
Temperature Ratings:		
Indoor (cooling)	(Deg. °F)	-22~122
Indoor (heating)	(Deg. °F)	-22~75

OPTIONAL ACCESSORIES

3rd Party Thermostat Interface Adapter 17222000A68532

INDOOR UNIT DATA

Fan Motor	(RLA)	1.5
Fan Motor	(W)	165

Air Flow & Sound Data:

Indoor Air Flow (Turbo/H/M/L/Q)	(CFM)	419.1 / 350.2 / 256.0 / 216.0 / 135.4
Indoor Noise Level (Turbo/H/M/L/Q)	(DBA)	32.5 / 32.5 / 30.5 / 28.5 / 26

Dimensions:

Indoor:		
Dimension (WxDxH)	(inch)	27.56 x 29.53 x 9.65
Packing(WxDxH)	(inch)	36.42 x 33.46 x 11.73
Unit weight	(lbs.)	64.15
Shipping Weight	(lbs.)	73.85

WARRANTY



5 years compressor
5 years parts

Indoor Unit Dimension

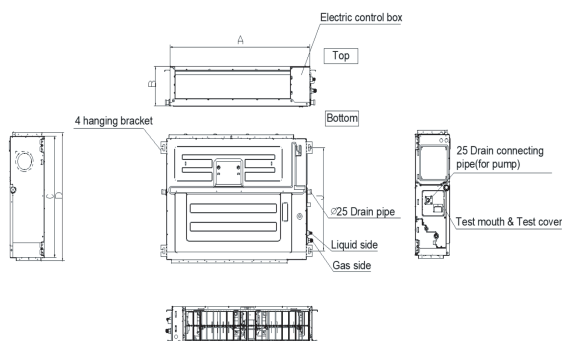

Capacity	W	D	H
12k	27.56	29.53	9.65