

Mitsutomo Submittal Data Sheet

R-454B 36K Slim Ducted Multi Zone Evap

Job Name: _____

Engineer: _____

Submitted By: _____

Date: _____

Unit Tag: _____

System Info & Features:

- Slim design
- Up to .8" Static Pressure
- Heating down to -22 deg
- Self diagnostics
- Super quiet
- 7 Day Programmable Wall Thermostat

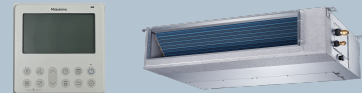

MODEL NUMBER	
Indoor unit:	HD-UG36-LA-Q
Certified:	

OPTIONAL ACCESSORIES	
3rd Party Thermostat Interface Adapter	17222000A68532

SYSTEM PERFORMANCE DATA		
Electrical:		
Normal Operational Voltage	(V, Ph, Hz)	208/230V,60Hz,1Ph
Connection wiring	Power: 14/3	Communication: 18/2 Stranded
Performance Data:		
Rated Capacity		36000
Min/Max Capacity		9800~37000
Moisture Removal	(L/H)	3.00

INDOOR UNIT DATA		
Fan Motor	(RLA)	3.2
Fan Motor	(W)	400
Air Flow & Sound Data:		
Indoor Air Flow (Turbo/H/M/L/Q)	(CFM)	1236.1 / 1059.5 / 941.8 / 765.2 / 765.2
Indoor Noise Level (Turbo/H/M/L/Q)	(DBA)	45 / 45 / 40 / 34 / 31

REFRIGERANT PIPE DATA		
Refrigerant Type		R454B
Liquid Side	(inch)	3/8
Gas Side	(inch)	3/4
Connection Method		Flared
Temperature Ratings:		
Indoor (cooling)	(Deg. °F)	-22~122
Indoor (heating)	(Deg. °F)	-22~75

Dimensions:		
Indoor:		
Dimension (WxDxH)	(inch)	47.24 x 29.53 x 11.81
Packing(WxDxH)	(inch)	56.10 x 33.86 x 14.13
Unit weight	(lbs.)	106.26
Shipping Weight	(lbs.)	120.37

WARRANTY	
	5 years compressor 5 years parts

Indoor Unit Dimension

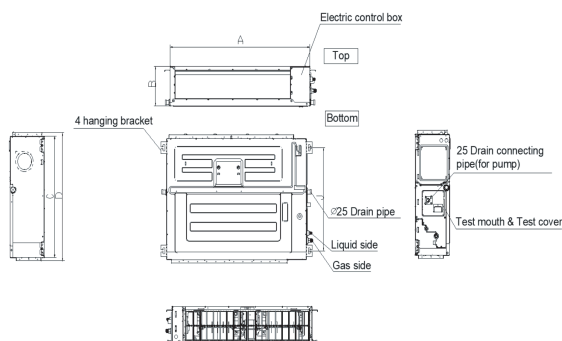

Capacity	W	D	H
36k	47.24	29.53	11.81