

Mitsutomo Submittal Data Sheet

R-454B 60k High Heat Slim Ducted Heat Pump

Job Name: _____

Engineer: _____

Submitted By: _____

Date: _____

Unit Tag: _____

System Info & Features:

- Slim design
- Up to .8" Static Pressure
- Heating down to -22 deg
- Self diagnostics
- Super quiet
- 7 Day Programmable Wall Thermostat



MODEL NUMBER	
Indoor unit:	HD-UG60-LA-Q
Outdoor unit:	HO-SG60-LA-Q
Certified:	

OPTIONAL ACCESSORIES	
3rd Party Thermostat Interface Adapter	17222000A68532

SYSTEM PERFORMANCE AND DATA	
Cooling Efficiencies and Performance	
SEER2	15.8
EER2	10.2
Rated Capacity	55000
Min/Max Capacity	14200~60000
Moisture Removal (L/H)	3.63
Standard Operating Range (F°)	-22~-122
Conditions:	Indoor: 80F° DB/67F° WB Outdoor: 95F° DB/75F° WB
Heating Efficiencies and Performance	
HSPF2-4	10.4
COP	3.74
1. @ 47F° Rated	60000
1. @ 47F° Min/Max Capacity	11200~66000
2. @ 17F° Rated	45000
3. @ 5F° Rated: Capacity / COP	53500/2.10
3. @ 5F° Max: Capacity	53500
Standard Operating Range (F°)	-22~-75
1. Conditions:	Indoor: 70F° DB/60F° WB Outdoor: 47F° DB/43F° WB
2. Conditions:	Indoor: 70F° DB/60F° WB Outdoor: 17F° DB/15F° WB
3. Conditions:	Indoor: 70F° DB/60F° WB Outdoor: 5F° DB/5F° WB

SPECIFICATIONS	
Indoor:	
Indoor Air Flow (Turbo/H/M/L/Q) (CFM)	2001.2 / 1706.9 / 1412.6 / 1118.3 / 1118.3
Indoor Noise Level (Turbo/H/M/L/Q) (DBA)	52 / 52 / 48 / 42 / 41
Heating Efficiencies and Performance	
Compressor Type	TWIN-ROTARY
Refrigerant	R454B
Refrigerant Oil Charge (OZ)	43.96
Refrigerant Oil	VG75
Outdoor Air Flow (Max) (CFM)	4237.9
Outdoor Noise Level (DBA)	63.0

DIMENSIONS	
Indoor:	
Dimension (W×D×H)	55.12 x 31.50 x 14.96
Package (W×D×H)	62.99 x 36.02 x 17.52
Unit Weight (lbs)	161.38
Shipping Weight (lbs)	178.13
Outdoor:	
Dimension (W×D×H)	37.48 x 16.34 x 52.48
Package (W×D×H)	43.11 x 19.49 x 58.27
Unit Weight (lbs)	230.38
Shipping Weight (lbs)	261.69

ELECTRICAL	
Power Supply	208/230V,60Hz,1Ph
System Min. Circuit Amps	44.00
Connection Wiring	Power: 14/3 Communication: 18/2 Stranded
System Max Over Current Protection (A)	45
Compressor (RLA)	26.8
Outdoor Fan Motor (RLA)	2.2
Outdoor Fan Motor (W)	85
Indoor Fan Motor (RLA)	4.0
Indoor Fan Motor (W)	560
System Power Input @ Cooling (W)	5400(1160 ~ 6120)
System Power Input @ Heating (W)	4700(795 ~5150)

REFRIGERANT PIPE DATA	
Liquid Size (in.)	3/8
Gas Size (in.)	3/4
Max. Piping Length (ft)	246.00
Max. Height Differencex (ft)	98.40
Max. Pre-charged Length (ft)	24.6
Refrigerant Pre-charged Amount (oz)	151.68
Additional Charge of Refrigerant (oz/ft)	0.32
Connection Method	Flared

WARRANTY	
	5 years compressor 5 years parts

Outdoor Unit Dimension

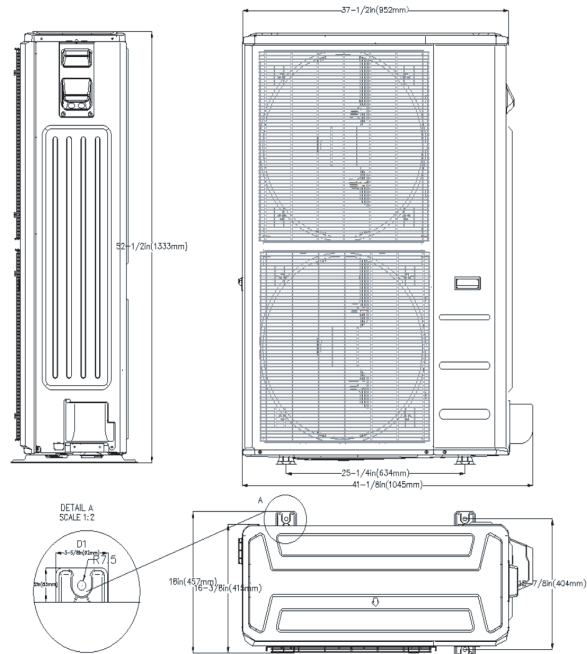

Indoor Unit Dimension (Internal Pump)

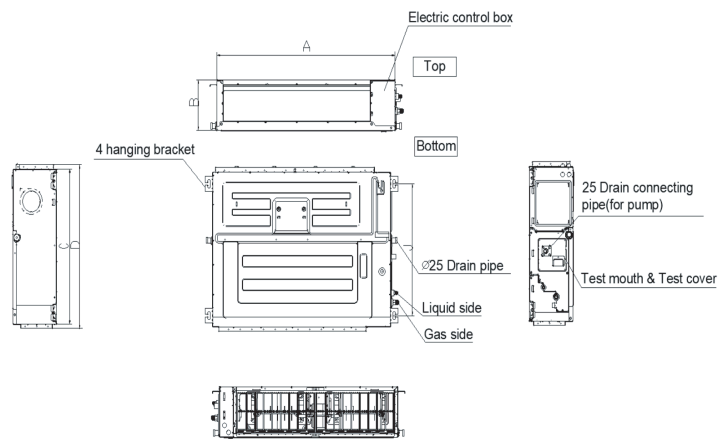

Capacity	W	D	H
55k	55.12	31.50	14.96