

# Mitsutomo

**MULTI-ZONE** OUTDOOR UNIT AIR CONDITIONER

# Installation Manual

RO-MT18-LA-Q

RO-MQ28-LA-Q

RO-MP36-LA-Q

RO-MS48-LA-Q

RO-MS60-LA-Q

HO-MT18-LA-Q

HO-MQ28-LA-Q

HO-MP36-LA-Q

HO-MS48-LA-Q

HO-MS60-LA-Q

**IMPORTANT NOTE:**



Read this manual carefully before installing or operating your new air conditioning unit. Make sure to save this manual for future reference.



# TABLE OF CONTENTS

SAFETY PRECAUTIONS .....	02
SPECIFICATIONS .....	14
PRODUCT OVERVIEW .....	15
PRODUCTION INSTALLATION .....	18
INSTALL OUTDOOR UNIT .....	20
REFRIGERANT PIPING CONNECTION .....	24
WIRING PRECAUTIONS .....	26
AIR EVACUATION .....	31
TEST RUN .....	34
FUNCTION OF AUTOMATIC WIRING/PIPING CORRECTION .....	35
OPERATION INSTRUCTIONS .....	36
MANUAL OPERATIONS AND MAINTENANCE .....	39
TROUBLESHOOTING .....	40
PACKING AND UNPACKING THE UNIT .....	43

## **Read this manual**

Inside you'll find many helpful hints on how to use and maintain your air conditioner properly. Just a little preventive care on your part can save you a great deal of time and money over the life of your air conditioner. These instructions may not cover every possible condition of use, so common sense and attention to safety is required when installing, operating and maintaining this product.

# Safety Precautions

It is really important you read Safety Precautions Before Operation and Installation. Incorrect installation due to ignoring instructions can cause serious damage or injury. The seriousness of potential damage or injuries is classified as either a WARNING or CAUTION.

## Explanation of Symbols



### WARNING

This symbol indicates the possibility of personal injury or loss of life.



### CAUTION

This symbol indicates the possibility of property damage or serious consequences.

## WARNING

This appliance is not intended for use by persons (including children) with reduced physical, sensory or mental capabilities, or lack of experience and knowledge, unless they have been given supervision or instruction concerning use of the appliance by a person responsible for their safety. Children should be supervised to ensure that they do not play with the appliance.

## ELECTRICAL WARNINGS

- Only use the specified wire. If the wire is damaged, it must be replaced by the manufacturer, its service agent or similarly qualified persons in order to avoid a hazard.
- The product must be properly grounded at the time of installation, or electric shock may occur.
- For all electrical work, follow all local and national wiring standards, regulations, and the Installation Manual. Connect cables tightly, and clamp them securely to prevent external forces from damaging the terminal. Improper electrical connections can overheat and cause fire, and may also cause shock. All electrical connections must be made according to the Electrical Connection Diagram located on the panels of the indoor and outdoor units.
- All wiring must be properly arranged to ensure that the control board cover can close properly. If the control board cover is not closed properly, it can lead to corrosion and cause the connection points on the terminal to heat up, catch fire, or cause electrical shock.
- Disconnection must be incorporated in the fixed wiring in accordance with the wiring rules.
- Do not share the electrical outlet with other appliances. Improper or insufficient power supply can cause fire or electric shock.
- If connecting power to fixed wiring, an all-pole disconnection device must be incorporated in the fixed wiring in accordance with the wiring rules.

## WARNINGS FOR PRODUCT INSTALLATION

- Turn off the air conditioner and disconnect the power before performing any installation or repairing. Failure to do so can cause electric shock.
- Installation must be performed by an authorized dealer or specialist. Defective installation can cause water leakage, electrical shock, or fire.
- Installation must be performed according to the installation instructions. Improper installation can cause water leakage, electrical shock, or fire. Contact an authorized service technician for repair or maintenance of this unit.
- This appliance shall be installed in accordance with national wiring regulations. Only use the included accessories, parts, and specified parts for installation.
- Using non-standard parts can cause water leakage, electrical shock, fire, and can cause the unit to fail.
- Install the unit in a firm location that can support the unit's weight. If the chosen location cannot support the unit's weight, or the installation is not done properly, the unit may drop and cause serious injury and damage.
- Install drainage piping according to the instructions in this manual. Improper drainage may cause water damage to your home and property.
- For units that have an auxiliary electric heater, do not install the unit within 1 meter (3 feet) of any combustible materials.
- For the units that have a wireless network function, the USB device access, replacement, maintenance operations must be carried out by professional staff.
- Do not install the unit in a location that may be exposed to combustible gas leaks. If combustible gas accumulates around the unit, it may cause fire.
- Do not turn on the power until all work has been completed.
- When moving or relocating the air conditioner, consult experienced service technicians for disconnection and reinstallation of the unit.
- How to install the appliance to its support, please read the information for details in "indoor unit installation" and "outdoor unit installation" sections.

## TAKE NOTE OF FUSE SPECIFICATIONS

The air conditioner's circuit board (PCB) is designed with a fuse to provide overcurrent protection. The specifications of the fuse are printed on the circuit board, for example : T3.15AL/250VAC, T5AL/250VAC, T3.15A/250VAC, T5A/250VAC, T20A/250VAC, T30A/250VAC, etc.

**NOTE:** Only the blast-proof ceramic fuse can be used.

## WARNING FOR USING FLAMMABLE REFRIGERANTS

- Do not use means to accelerate the defrosting process or to clean, other than those recommended by the manufacturer.
- The appliance shall be stored in a room without continuously operating ignition sources (for example: open flames, an operating gas appliance or an operating electric heater).
- Do not pierce or burn.
- Be aware that refrigerants may not contain an odour.
- LEAK DETECTION SYSTEM installed. Unit must be powered except for service. For the unit with refrigerant sensor, when the refrigerant sensor detects refrigerant leakage, the indoor unit will display an error code and emit a buzzing sound, the compressor of outdoor unit will immediately stop, and the indoor fan will start running. The service life of the refrigerant sensor is 15 years. When the refrigerant sensor malfunctions, the indoor unit will display the error code "FHCC". The refrigerant sensor cannot be repaired and can only be replaced by the manufacture. It shall only be replaced with the sensor specified by the manufacture.

## For R454B refrigerant charge amount and minimum room area:

Requirements for room area limits using R454B refrigerant in unventilated areas: Our multiple systems are all confirmed to meet the requirement of Enhanced Tightness Refrigerating Systems. Units installed at a height not exceeding 5.9ft/1.8m above the ground are usually equipped with refrigerant sensor, which minimum room area ( $A_{min}$ ) of operating or storage should be determined according to refrigerant charge ( $m_c$ ) or releasable charge ( $m_{rel}$ ) of system, as specified in the following table. The table is also applicable for those units without refrigerant sensor but its installation heights are between 5.9ft/1.8m and 7.2ft/2.2m. The height of the room cannot be less than 7.2ft /2.2m.

$m_c$ or $m_{rel}$ [oz/kg]	$A_{min}$ [ft <sup>2</sup> /m <sup>2</sup> ]	$m_c$ or $m_{rel}$ [oz/kg]	$A_{min}$ [ft <sup>2</sup> /m <sup>2</sup> ]
≤62.7/1.776	12/1.10	119.9/3.4	112/10.44
63.5/1.8	60/5.53	127/3.6	119/11.06
70.5/2.0	66/6.14	134/3.8	126/11.67
77.6/2.2	73/6.76	141.1/4.0	132/12.29
84.6/2.4	79/7.37	148.1/4.2	139/12.9
91.7/2.6	86/7.99	155.2/4.4	145/13.51
98.8/2.8	93/8.6	162.2/4.6	152/14.13
105.8/3.0	99/9.21	169.3/4.8	159/14.74
112.9/3.2	106/9.83	176.4/5.0	165/15.36

Units installed higher than 7.2ft/2.2m have a looser installation area requirement, as specified in the following table.

$A_{min}$ [ft <sup>2</sup> /m <sup>2</sup> ]	$h_{inst}$ [ft/m]				
	7.5/2.3	7.9/2.4	8.5/2.6	9.2/2.8	9.8/3.0
$m_c$ or $m_{REL}$ [oz/kg]					
≤62.7/1.776	12/1.10				
63.5/1.8	57/5.29	55/5.07	50/4.68	47/4.34	44/4.05
70.5/2	63/5.88	61/5.63	56/5.2	52/4.83	48/4.5
77.6/2.2	70/6.46	67/6.19	62/5.72	57/5.31	53/4.95
84.6/2.4	76/7.05	73/6.76	67/6.24	62/5.79	58/5.41
91.7/2.6	82/7.64	79/7.32	73/6.76	67/6.27	63/5.86
98.8/2.8	89/8.23	85/7.88	78/7.28	73/6.76	68/6.31
105.8/3	95/8.81	91/8.45	84/7.8	78/7.24	73/6.76
112.9/3.2	101/9.4	97/9.01	90/8.32	83/7.72	78/7.21
119.9/3.4	107/9.99	103/9.57	95/8.84	88/8.2	82/7.66
127/3.6	114/10.58	109/10.14	101/9.36	94/8.69	87/8.11
134/3.8	120/11.16	115/10.7	106/9.88	99/9.17	92/8.56
141.1/4	126/11.75	121/11.26	112/10.4	104/9.65	97/9.01
148.1/4.2	133/12.34	127/11.82	117/10.91	109/10.14	102/9.46
155.2/4.4	139/12.93	133/12.39	123/11.43	114/10.62	107/9.91
162.2/4.6	145/13.51	139/12.95	129/11.95	119/11.1	111/10.36
169.3/4.8	152/14.1	145/13.51	134/12.47	125/11.58	116/10.81
176.4/5	158/14.69	152/14.08	140/12.99	130/12.07	121/11.26

Notes	<p><b>A<sub>min</sub></b> is the required minimum room area in ft<sup>2</sup>/m<sup>2</sup></p> <p><b>m<sub>c</sub></b> is the actual refrigerant charge in the system in oz/kg</p> <p><b>m<sub>REL</sub></b> is the refrigerant releasable charge in oz/kg, only used for releasable charge limited system.</p> <p><b>h<sub>inst</sub></b> is the height of the bottom of the appliance relative to the floor of the room after installation in ft/m.</p> <p><b>WARNING:</b> The minimum room area or minimum room area of conditioned space is based on releasable charge and total system refrigerant charge. If the refrigerant charge and installation height are not exactly the values in the table, the closest upward refrigerant charge and the closest downward height should be referenced.</p>
-------	---

### For releasable charge limited system:

SAFETY SHUT-OFF VALVES are used in some multiple outdoor units, as shown in the following table, for the purposes of limiting the releasable charge, which are activated by refrigerant detection system.

#### **WARNING**

SAFETY SHUT-OFF VALVES default to fully closed position when the appliance is de-energized, so refrigerant will not be completely released even when it was dismantled. Ensure the complete release of refrigerant through one of following methods before repairing the machine.

Method 1: Release refrigerant while the machine is powered on.

Method 2: Remove the coil of safety shut-off valve before power-off.

Method 3: Manually open the safety shut-off valve using a magnetic ring.

Model	Outdoor unit	Releasable charge limited system
18K Regular	RO-MT18-LA-Q	No
18K Hyper Heat	HO-MT18-LA-Q	Yes
27K Regular	RO-MQ28-LA-Q	No
27K Hyper Heat	HO-MQ28-LA-Q	Yes
36K Regular	RO-MP36-LA-Q	No
36K Hyper Heat	HO-MP36-LA-Q	Yes
48K Regular	RO-MS48-LA-Q	No
48K Hyper Heat	HO-MS48-LA-Q	Yes
60K Regular	RO-MS60-LA-Q	No
60K Hyper Heat	HO-MS60-LA-Q	Yes

Releasable charge limited system is applicable only when all indoor units were in below table. Releasable charge (mrel) of system should be calculated based on internal volume of all indoor units and connecting pipes. Each indoor units correspond to a releasable charge as following table, add them up based on the combination of indoor units, and then add to the basic releasable charge of 7.196oz/0.204kg, you will get the total releasable charge of system.

**NOTE**

The calculation is based on the standard connection pipe length of 24.6ft/7.5m for each indoor units, an extra releasable charge should be added for per meter exceeding 24.6ft/7.5m.  
 If calculated releasable charge (mrel) is higher than refrigerant charge (mc), room area shall be calculated based on refrigerant charge (mc).

Model	Indoor unit	Releasable charge for each unit	Basic releasable charge	Extra releasable charge	Total releasable charge	
6K	HW-UZ06-LA-Q	11.887oz/0.337kg	7.196oz/0.204 kg (Leakage at a rate of 6.8 g/s for 30 s)	0oz/kg when connection pipe length for each indoor units are within 24.6ft/7.5m.	Add 3 parts of releasable charge based on the combination of indoor units, you will get the total releasable charge of system.	
9K	HW-UZ09-LA-Q	13.475oz/0.382kg				
12K	HW-UZ12-LA-Q	13.475oz/0.382kg				
18K	HW-UZ18-LA-Q	17.884oz/0.507kg				
24K	HW-UZ24-LA-Q	26.209oz/0.743kg				
33K	HW-UZ33-LA-Q	38.131oz/1.081kg				
9K	RW-SZ09-LA-Q	11.887oz/0.337kg				
12K	RW-SZ12-LA-Q	12.311oz/0.349kg				
18K	RW-SZ18-LA-Q	16.861oz/0.478kg				
24K	RW-SZ24-LA-Q	26.209oz/0.743kg				
30K	HW-UZ30-LA-Q	38.131oz/1.081kg				0.705oz/0.020kg per meter exceeding 24.6ft/7.5m for each 6/9/12/18K unit.
36K	HW-UZ36-LA-Q	38.131oz/1.081kg				
9K	S-RW-SZ09-LA-Q	8.572oz/0.243kg				
12K	S-RW-SZ12-LA-Q	8.572oz/0.243kg				
18K	S-RW-SZ18-LA-Q	15.485oz/0.439kg				
24K	S-RW-SZ24-LA-Q	24.903oz/0.706kg				
6K	HD-UZ06-LA-Q	12.346oz/0.350kg		1.764oz/0.050kg per meter exceeding 24.6ft/7.5m for each 24/36K unit.		
9K	HD-UZ09-LA-Q	12.346oz/0.350kg				
12K	HD-UZ12-LA-Q	12.346oz/0.350kg				
18K	HD-UZ18-LA-Q	17.320oz/0.491kg				
9K	S-HD-UZ09-LA-Q	11.464oz/0.325kg				
12K	S-HD-UZ12-LA-Q	11.464oz/0.325kg				
18K	S-HD-UZ18-LA-Q	15.803oz/0.448kg				
24K	HD-UZ24LA-Q	24.127oz/0.684kg				

Model	Indoor unit	Releasable charge for each unit	Basic releasable charge	Extra releasable charge	Total releasable charge
18K	HV-UZ18-LA-Q	24.163oz/0.685kg			
24K	HV-UZ24-LA-Q	32.487oz/0.921kg			
30K	HV-UZ30-LA-Q	47.796oz/1.355kg			
36K	HV-UZ36-LA-Q	47.796oz/1.355kg			
9K	HC-UZ09-LA-Q	17.425oz/0.494kg			
12K	HC-UZ12-LA-Q	17.425oz/0.494kg			
18K	HC-UZ18-LA-Q	18.095oz/0.513kg			
24K	HC-UZ24-LA-Q	29.560oz/0.838kg			
6K	HJ-UZ06-LA-Q	16.579oz/0.470kg			
9K	HJ-UZ09-LA-Q	16.579oz/0.470kg			
12K	HJ-UZ12-LA-Q	16.579oz/0.470kg			
18K	HJ-UZ18-LA-Q	17.284oz/0.490kg			
18K	HF-UZ18-LA-Q	16.050oz/0.455kg			
24K	HF-UZ24-LA-Q	29.489oz/0.836kg			
9K	HL-UZ09-LA-Q	14.215oz/0.403kg			
12K	HL-UZ12-LA-Q	14.215oz/0.403kg			
16K	HL-UZ16-LA-Q	14.921oz/0.423kg			

## 1. **Installation** (where refrigerant pipes are allowed)

- Any person who is involved with working on or breaking into a refrigerant circuit should hold a current valid certificate from an industry-accredited assessment authority, which authorizes their competence to handle refrigerants safely in accordance with an industry recognized assessment specification.
- Maintenance and repair requiring the assistance of other skilled personnel shall be carried out under the supervision of the person competent in the use of flammable refrigerants.
- That the installation of pipe-work shall be kept to a minimum.
- That pipe-work shall be protected from physical damage.
- Where refrigerant pipes shall be compliance with national gas regulations.
- That mechanical connections shall be accessible for maintenance purposes.
- Be more careful that foreign matter (oil, water, etc.) does not enter the piping. Also, when storing the piping, securely seal the opening by pinching, taping, etc.
- All working procedure that affects safety means shall only be carried by competent persons.
- Appliance shall be stored in a well-ventilated area where the room size corresponds to the room area as specific for operation.
- Joints shall be tested with detection equipment with a capability of 5 g/year of refrigerant or better, with the equipment in standstill and under operation or under a pressure of at least these standstill or operation conditions after installation. Detachable joints shall NOT be used in the indoor side of the unit (brazed, welded joint could be used).
- In cases that require mechanical ventilation, ventilation openings shall be kept clear of obstruction.
- LEAK DETECTION SYSTEM installed. Unit must be powered except for service. For the unit with refrigerant sensor, when the refrigerant sensor detects refrigerant leakage, the indoor unit will display an error code and emit a buzzing sound, the compressor of outdoor unit will immediately stop, and the indoor fan will start running. The service life of the refrigerant sensor is 15 years. When the refrigerant sensor malfunctions, the indoor unit will display the error code "FHCC". The refrigerant sensor cannot be repaired and can only be replaced by the manufacture. It shall only be replaced with the sensor specified by the manufacture.

## 2. **When a FLAMMABLE REFRIGERANT is used**, the requirements for installation space of appliance and/or ventilation requirements are determined according to

- the mass charge amount (M) used in the appliance,
- the installation location,
- the type of ventilation of the location or of the appliance.
- piping material, pipe routing, and installation shall include protection from physical damage in operation and service, and be in compliance with national and local codes and standards, such as ASHRAE 15, IAPMO Uniform Mechanical Code, ICC International Mechanical Code, or CSA B52. All field joints shall be accessible for inspection prior to being covered or enclosed.
- that protection devices, piping, and fittings shall be protected as far as possible against adverse environmental effects, for example, the danger of water collecting and freezing in relief pipes or the accumulation of dirt and debris;
- that piping in refrigeration systems shall be so designed and installed to minimize the likelihood of hydraulic shock damaging the system;
- that steel pipes and components shall be protected against corrosion with a rustproof coating before applying any insulation;
- that precautions shall be taken to avoid excessive vibration or pulsation;
- the minimum floor area of the room shall be mentioned in the form of a table or a single figure without reference to a formula;
- after completion of field piping for split systems, the field pipework shall be pressure tested with an inert gas and then vacuum tested prior to refrigerant charging, according to the following requirements:
  - a. The minimum test pressure for the low side of the system shall be the low side design pressure and the minimum test pressure for the high side of the system

shall be the high side design pressure, unless the high side of the system cannot be isolated from the low side of the system in which case the entire system shall be pressure tested to the low side design pressure.

- b. The test pressure after removal of pressure source shall be maintained for at least 1 h with no decrease of pressure indicated by the test gauge, with test gauge resolution not exceeding 5% of the test pressure.
  - c. During the evacuation test, after achieving a vacuum level specified in the manual or less, the refrigeration system shall be isolated from the vacuum pump and the pressure shall not rise above 1500 microns within 10 min. The vacuum pressure level shall be specified in the manual, and shall be the lessor of 500 microns or the value required for compliance with national and local codes and standards, which may vary between residential, commercial, and industrial buildings.
- field-made refrigerant joints indoors shall be tightness tested according to the following requirements: The test method shall have a sensitivity of 5 grams per year of refrigerant or better under a pressure of at least 0, 25 times the maximum allowable pressure. No leak shall be detected.

### **3. Qualification of workers**

Any maintenance, service and repair operations must be required qualification of the working personnel. Every working procedure that affects safety means shall only be carried out by competent persons that joined the training and achieved competence should be documented by a certificate. The training of these procedures is carried out by national training organizations or manufacturers that are accredited to teach the relevant national competency standards that may be set in legislation. All training shall follow the ANNEX HH requirements of UL 60335-2-40 4th Edition.

Examples for such working procedures are:

- breaking into the refrigerating circuit;
- opening of sealed components;
- opening of ventilated enclosures.

## **Information Servicing**

### **1. Checks to the area**

Prior to beginning work on systems containing flammable refrigerants, safety checks are necessary to ensure that the risk of ignition is minimized. For repair to the refrigerating system, the following precautions shall be complied with prior to conducting work on the system.

### **2. Work procedure**

Works shall be undertaken under a controlled procedure so as to minimize the risk of a flammable gas or vapour being present while the work is being performed.

### **3. General work area**

All maintenance staff and others working in the local area shall be instructed on the nature of work being carried out. work in confined spaces shall be avoided.

### **4. Checking for presence of refrigerant**

The area shall be checked with an appropriate refrigerant detector prior to and during work, to ensure the technician is aware of potentially flammable atmospheres. Ensure that the leak detection equipment being used is suitable for use with flammable refrigerants, i.e., no sparking, adequately sealed or intrinsically safe.

### **5. Presence of fire extinguisher**

If any hot work is to be conducted on the refrigeration equipment or any associated parts, appropriate fire extinguishing equipment shall be available to hand. Have a dry power or CO<sub>2</sub> fire extinguisher adjacent to the charging area.

## **6. No ignition sources**

No person carrying out work in relation to a REFRIGERATING SYSTEM which involves exposing any pipe work shall use any sources of ignition in such a manner that it may lead to the risk of fire or explosion. All possible ignition sources, including cigarette smoking, should be kept sufficiently far away from the site of installation, repairing, removing and disposal, during which refrigerant can possibly be released to the surrounding space. Prior to work taking place, the area around the equipment is to be surveyed to make sure that there are no flammable hazards or ignition risks. "No Smoking" signs shall be displayed.

## **7. Ventilated area**

Ensure that the area is in the open or that it is adequately ventilated before breaking into the system or conducting any hot work. A degree of ventilation shall continue during the period that the work is carried out. The ventilation should safely disperse any released refrigerant and preferably expel it externally into the atmosphere.

## **8. Checks to the refrigeration equipment**

Where electrical components are being changed, they shall be fit for the purpose and to the correct specification. At all times the manufacturer's maintenance and service guidelines shall be followed. If in doubt consult the manufacturer's technical department for assistance. The following checks shall be applied to installations using FLAMMABLE REFRIGERANTS:

- the actual refrigerant charge is in accordance with the room size within which the refrigerant containing parts are installed;
- the ventilation machinery and outlets are operating adequately and are not obstructed;
- if an indirect refrigerating circuit is being used, the secondary circuits shall be checked for the presence of refrigerant;
- marking to the equipment continues to be visible and legible, marking and signs that are illegible shall be corrected;
- refrigeration pipe or components are installed in a position where they are unlikely to be exposed to any substance which may corrode refrigerant containing components, unless the components are constructed of materials which are inherently resistant to being corroded or are suitably protected against being so corroded.

## **9. Checks to electrical devices**

Repair and maintenance to electrical components shall include initial safety checks and component inspection procedures. If a fault exists that could compromise safety, then no electrical supply shall be connected to the circuit until it is satisfactorily dealt with. If the fault cannot be corrected immediately but it is necessary to continue operation, and adequate temporary solution shall be used. This shall be reported to the owner of the equipment so all parties are advised.

### **Initial safety checks shall include:**

- that capacitors are discharged: this shall be done in a safe manner to avoid possibility of sparking;
- that there no live electrical components and wiring are exposed while charging, recovering or purging the system;
- that there is continuity of earth bonding.

## **10. Sealed electrical components shall be replaced if it's damage.**

## **11. Intrinsically safe components must be replaced if it's damage.**

## **12. Cabling**

Check that cabling will not be subject to wear, corrosion, excessive pressure, vibration, sharp edges or any other adverse environmental effects. The check shall also take into account the effects of aging or continual vibration from sources such as compressors or fans.

## **13. Detection of flammable refrigerants**

Under no circumstances shall potential sources of ignition be used in the searching for or detection of refrigerant leaks. A halide torch (or any other detector using a naked flame) shall not be used.

The following leak detection methods are deemed acceptable for refrigerant systems. Electronic leak detectors may be used to detect refrigerant leaks but, in the case of FLAMMABLE REFRIGERANTS, the sensitivity may not be adequate, or may need re-calibration. (Detection equipment shall be calibrated in a refrigerant-free area.) Ensure that the detector is not a potential source of ignition and is suitable for the refrigerant used. Leak detection equipment shall be set at a percentage of the LFL of the refrigerant and shall be calibrated to the refrigerant employed, and the appropriate percentage of gas (25 % maximum) is confirmed.

Leak detection fluids are also suitable for use with most refrigerants but the use of detergents containing chlorine shall be avoided as the chlorine may react with the refrigerant and corrode the copper pipe-work.

NOTE Examples of leak detection fluids are

- bubble method,
- fluorescent method agents.

If a leak is suspected, all naked flames shall be removed/extinguished.

If a leakage of refrigerant is found which requires brazing, all of the refrigerant shall be recovered from the system, or isolated (by means of shut off valves) in a part of the system remote from the leak. See the following instructions of removal of refrigerant.

## **14. Removal and evacuation**

When breaking into the refrigerant circuit to make repairs - or for any other purpose conventional procedures shall be used. However, for flammable refrigerants it is important that best practice be followed, since flammability is a consideration.

The following procedure shall be adhered to:

- safely remove refrigerant following local and national regulations;
- evacuate;
- purge the circuit with inert gas (optional for A2L);
- evacuate (optional for A2L);
- continuously flush or purge with inert gas when using flame to open circuit; and open the circuit.

The refrigerant charge shall be recovered into the correct recovery cylinders if venting is not allowed by local and national codes. For appliances containing flammable refrigerants, the system shall be purged with oxygen-free nitrogen to render the appliance safe for flammable refrigerants. This process might need to be repeated several times. Compressed air or oxygen shall not be used for purging refrigerant systems.

For appliances containing flammable refrigerants, refrigerants purging shall be achieved by breaking the vacuum in the system with oxygen-free nitrogen and continuing to fill until the working pressure is achieved, then venting to atmosphere, and finally pulling down to a vacuum (optional for A2L). This process shall be repeated until no refrigerant is within the system (optional for A2L). When the final oxygen-free nitrogen charge is used, the system shall be vented down to atmospheric pressure to enable work to take place.

The outlet for the vacuum pump shall not be close to any potential ignition sources, and ventilation shall be available.

## 15. Charging procedures

In addition to conventional charging procedures, the following requirements shall be followed:

- Works shall be undertaken with appropriate tools only (In case of uncertainty, please consult the manufacturer of the tools for use with flammable refrigerants)
- Ensure that contamination of different refrigerants does not occur when using charging equipment. Hoses or lines shall be as short as possible to minimize the amount of refrigerant contained in them.
- Cylinders shall be kept upright.
- Ensure that the refrigeration system is earthed prior to charging the system with refrigerant.
- Label the system when charging is complete (if not already).
- Extreme care shall be taken not to overfill the refrigeration system.
- Prior to recharging the system it shall be pressure tested with oxygen free nitrogen (OFN). The system shall be leak tested on completion of charging but prior to commissioning. A follow up leak test shall be carried out prior to leaving the site.

## 16. Decommissioning

Before carrying out this procedure, it is essential that the technician is completely familiar with the equipment and all its detail. It is recommended good practice that all refrigerants are recovered safely. Prior to the task being carried out, an oil and refrigerant sample shall be taken in case analysis is required prior to re-use of recovered refrigerant. It is essential that electrical power is available before the task is commenced.

- a) Become familiar with the equipment and its operation.
- b) Isolate system electrically
- c) Before attempting the procedure ensure that:
  - mechanical handling equipment is available, if required, for handling refrigerant cylinders;
  - all personal protective equipment is available and being used correctly;
  - the recovery process is supervised at all times by a competent person;
  - recovery equipment and cylinders conform to the appropriate standards.
- d) Pump down refrigerant system, if possible.
- e) If a vacuum is not possible, make a manifold so that refrigerant can be removed from various parts of the system.
- f) Make sure that cylinder is situated on the scales before recovery takes place.
- g) Start the recovery machine and operate in accordance with instructions.
- h) Do not overfill cylinders (no more than 80 % volume liquid charge)
- i) Do not exceed the maximum working pressure of the cylinder, even temporarily.
- j) When the cylinders have been filled correctly and the process completed, make sure that the cylinders and the equipment are removed from site promptly and all isolation valves on the equipment are closed off.
- k) Recovered refrigerant shall not be charged into another refrigeration system unless it has been cleaned and checked.

## 17. Labelling

Equipment shall be labelled stating that it has been de-commissioned and emptied of refrigerant. The label shall be dated and signed. For appliances containing FLAMMABLE REFRIGERANTS, ensure that there are labels on the equipment stating the equipment contains FLAMMABLE REFRIGERANT.

## 18. Recovery

When removing refrigerant from a system, either for servicing or decommissioning, it is recommended good practice that all refrigerants are removed safely. When transferring refrigerant into cylinders, ensure that only appropriate refrigerant recovery cylinders are employed. Ensure that the correct number of cylinders for holding the total system charge is available. All cylinders to be used are designated

for the recovered refrigerant and labelled for that refrigerant (i. e. special cylinders for the recovery of refrigerant). Cylinders shall be complete with pressure-relief valve and associated shut-off valves in good working order. Empty recovery cylinders are evacuated and, if possible, cooled before recovery occurs.

The recovery equipment shall be in good working order with a set of instructions concerning the equipment that is at hand and shall be suitable for the recovery of the flammable refrigerant. If in doubt, the manufacturer should be consulted. In addition, a set of calibrated weighing scales shall be available and in good working order. Hoses shall be complete with leak-free disconnect couplings and in good condition.





The recovered refrigerant shall be processed according to local legislation in the correct recovery cylinder, and the relevant waste transfer note arranged. Do not mix refrigerants in recovery units and especially not in cylinders.

If compressors or compressor oils are to be removed, ensure that they have been evacuated to an acceptable level to make certain that flammable refrigerant does not remain within the lubricant. The compressor body shall not be heated by an open flame or other ignition sources to accelerate this process. When oil is drained from a system, it shall be carried out safely.

### 19. Transportation, marking and storage for units

1. Transport of equipment containing flammable refrigerants  
Compliance with the transport regulations.
2. Marking of equipment using signs  
Compliance with local regulations.
3. Disposal of equipment using flammable refrigerants  
Compliance with national regulations.
4. Storage of equipment/appliances  
The storage of equipment should be in accordance with the manufacturer's instructions.
5. Storage of packed (unsold) equipment  
Storage package protection should be constructed such that mechanical damage to the equipment inside the package will not cause a leak of the refrigerant charge.  
The maximum number of pieces of equipment permitted to be stored together will be determined by local regulations.

### Explanation of symbols displayed on the indoor unit or outdoor unit

	<p><b>WARNING</b></p>	<p>This symbol shows that this appliance used a flammable refrigerant. If the refrigerant is leaked and exposed to an external ignition source, there is a risk of fire.</p>
	<p><b>CAUTION</b></p>	<p>This symbol shows that the operation manual should be read carefully.</p>
	<p><b>CAUTION</b></p>	<p>This symbol shows that a service personnel should be handling this equipment with reference to the installation manual.</p>
	<p><b>CAUTION</b></p>	
	<p><b>CAUTION</b></p>	<p>This symbol shows that information is available such as the operating manual or installation manual.</p>

# SPECIFICATIONS

Number of units that can be used together	Connected units	1-6 units
Compressor stop/start frequency	Stop time	3 min or more
Power source voltage	voltage fluctuation	within 310% of rated voltage
	voltage drop during start	within 315% of rated voltage
	interval unbalance	within 33% of rated voltage

**Models without quick connectors** Unit: ft/m

	1 drive 2	1 drive 3	1 drive 4	1 drive 5	1 drive 6
Max. length for all rooms	131/40	197/60	262/80	262/80	262/80
Max. length for one indoor unit	82/25	98/30	115/35	115/35	115/35
Max. height different between indoor and outdoor unit	49/15	49/15	49/15	49/15	49/15
Max. height different between indoor units	33/10	33/10	33/10	33/10	33/10

**Models with quick connectors** Unit: ft/m

	1 drive 2	1 drive 3	1 drive 4	1 drive 5	1 drive 6
Max. length for all rooms	123/37.5	172/52.5	221/67.5	221/67.5	221/67.5
Max. length for one indoor unit	73/22.5	73/22.5	73/22.5	73/22.5	73/22.5
Max. height different between indoor and outdoor unit	33/10	33/10	33/10	33/10	33/10
Max. height different between indoor units	24/7.5	24/7.5	24/7.5	24/7.5	24/7.5

When installing multiple indoor units with a single outdoor unit, ensure that the length of the refrigerant pipe and the drop height between the indoor and outdoor units meet the requirements illustrated in the following diagram:

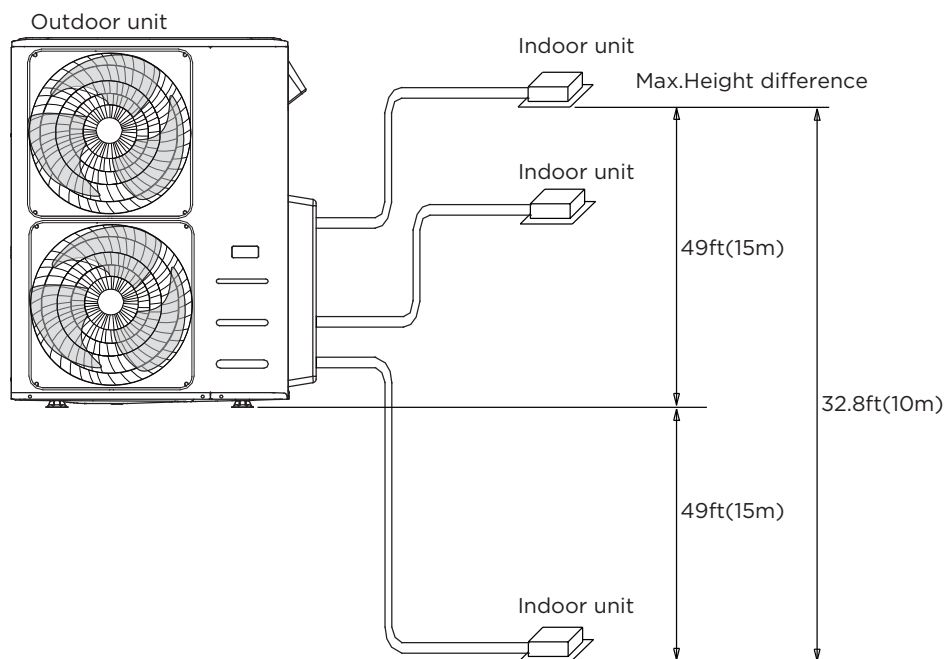

# PRODUCT OVERVIEW

(A) Wall-mounted type

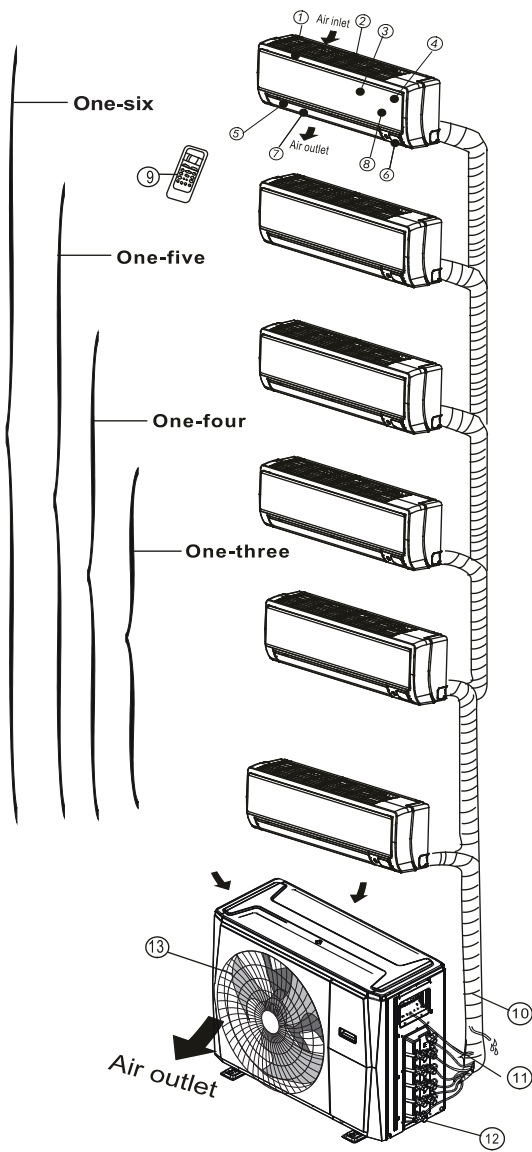

**Indoor unit**

- 1. Panel frame
- 2. Rear air intake grille
- 3. Front panel
- 4. Air purifying filter & Air filter (behind)
- 5. Horizontal louver
- 6. LCD display window
- 7. Vertical louver
- 8. Manual control button (behind)
- 9. Remote controller holder

**Outdoor unit**

- 10. Drain hose, refrigerant connecting pipe
- 11. Connective cable
- 12. Stop valve
- 13. Fan hood

(B) Duct / Ceiling type

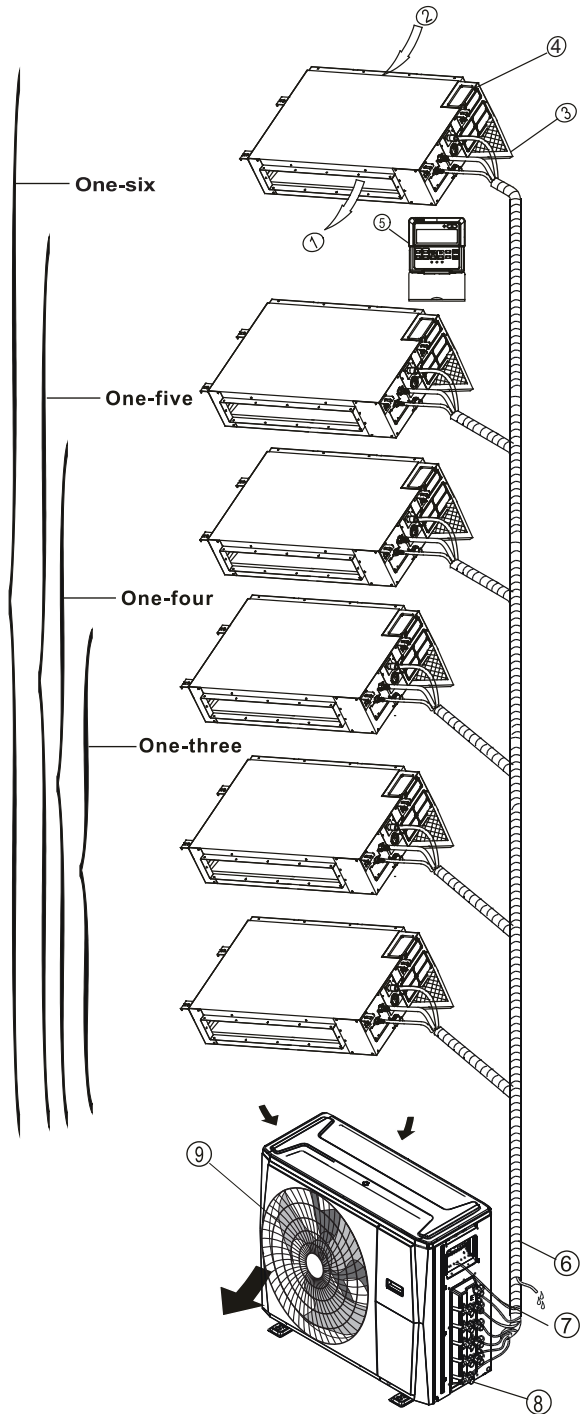

**Indoor unit**

- 1. Air outlet
- 2. Air inlet
- 3. Air filter
- 4. Electric control cabinet
- 5. Wire controller

**Outdoor unit**

- 6. Drain hose, refrigerant connecting pipe
- 7. Connective cable
- 8. Stop valve
- 9. Fan hood

**(C) Floor and standing type (Console)**

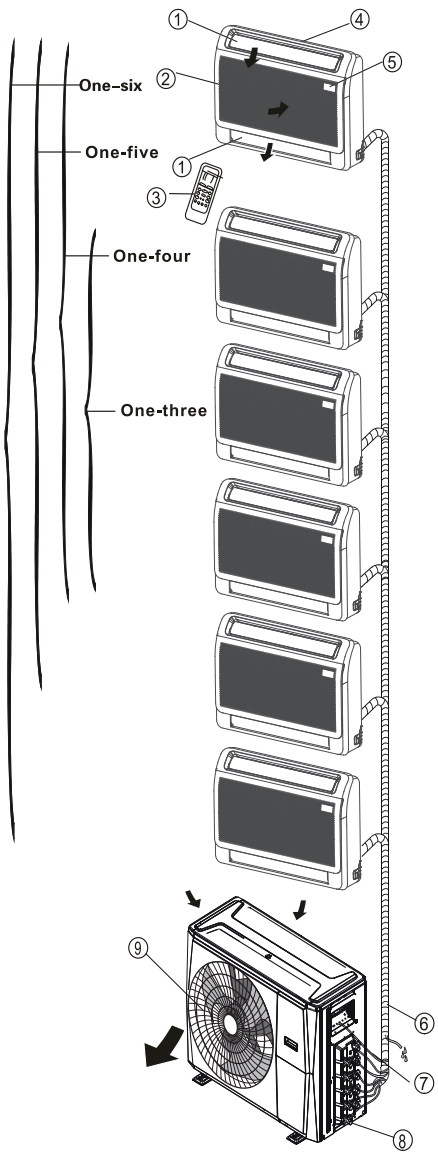

**(D) Compact four-way cassette type**

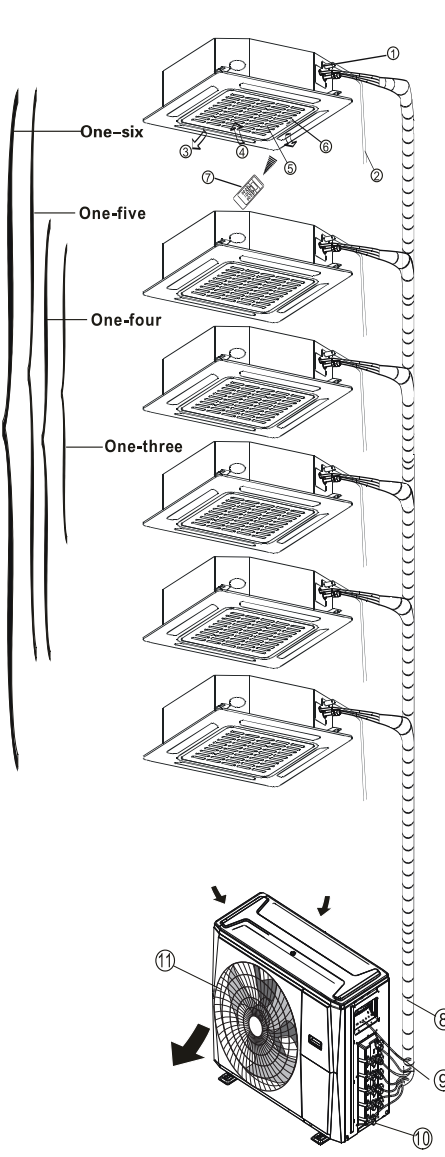

**(E) One-way cassette type**

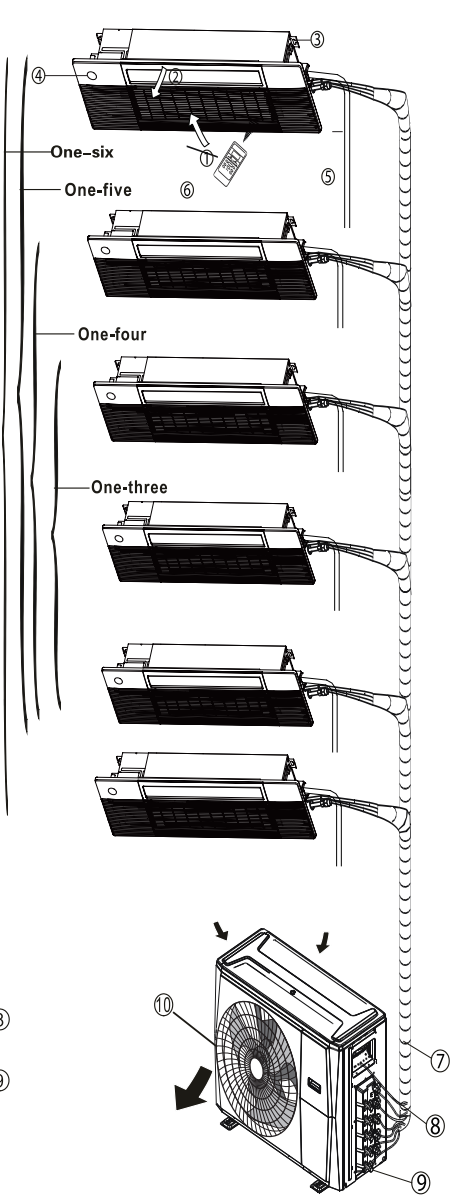

**Indoor unit**

- 1. Air flow louver (at air outlet)
- 2. Air inlet
- 3. Remote controller
- 4. Installation part
- 5. Display panel

**Outdoor unit**

- 6. Drain hose, refrigerant connecting piping
- 7. Connective cable
- 8. Stop valve
- 9. Fan hood

**Indoor unit**

- 1. Drain pump (drain water from indoor unit)
- 2. Drain hose
- 3. Air outlet
- 4. Air inlet
- 5. Air-in grill
- 6. Display panel
- 7. Remote controller

**Outdoor unit**

- 8. Refrigerant connecting piping
- 9. Connecting cable
- 10. Stop valve
- 11. Fan hood

**Indoor unit**

- 1. Air inlet (with air filter in it)
- 2. Air flow louver (at air outlet)
- 3. Installation part
- 4. Display panel
- 5. Drain pipe
- 6. Remote controller

**Outdoor unit**

- 7. Refrigerant connecting piping
- 8. Connecting cable
- 9. Stop valve
- 10. Fan hood

**NOTE:**

- For multi-split type air conditioners, one outdoor unit can be matched to different types of indoor units. All of the pictures in this manual are for demonstration purposes only. Your air conditioner may be slightly different, if similar in shape.
- Necessity to allow disconnection of the appliance from the supply after installation, unless the appliance incorporates a switch complying. The disconnection may be achieved by having the plug accessible or by incorporating a switch in the fixed wiring in accordance with the wiring rules.



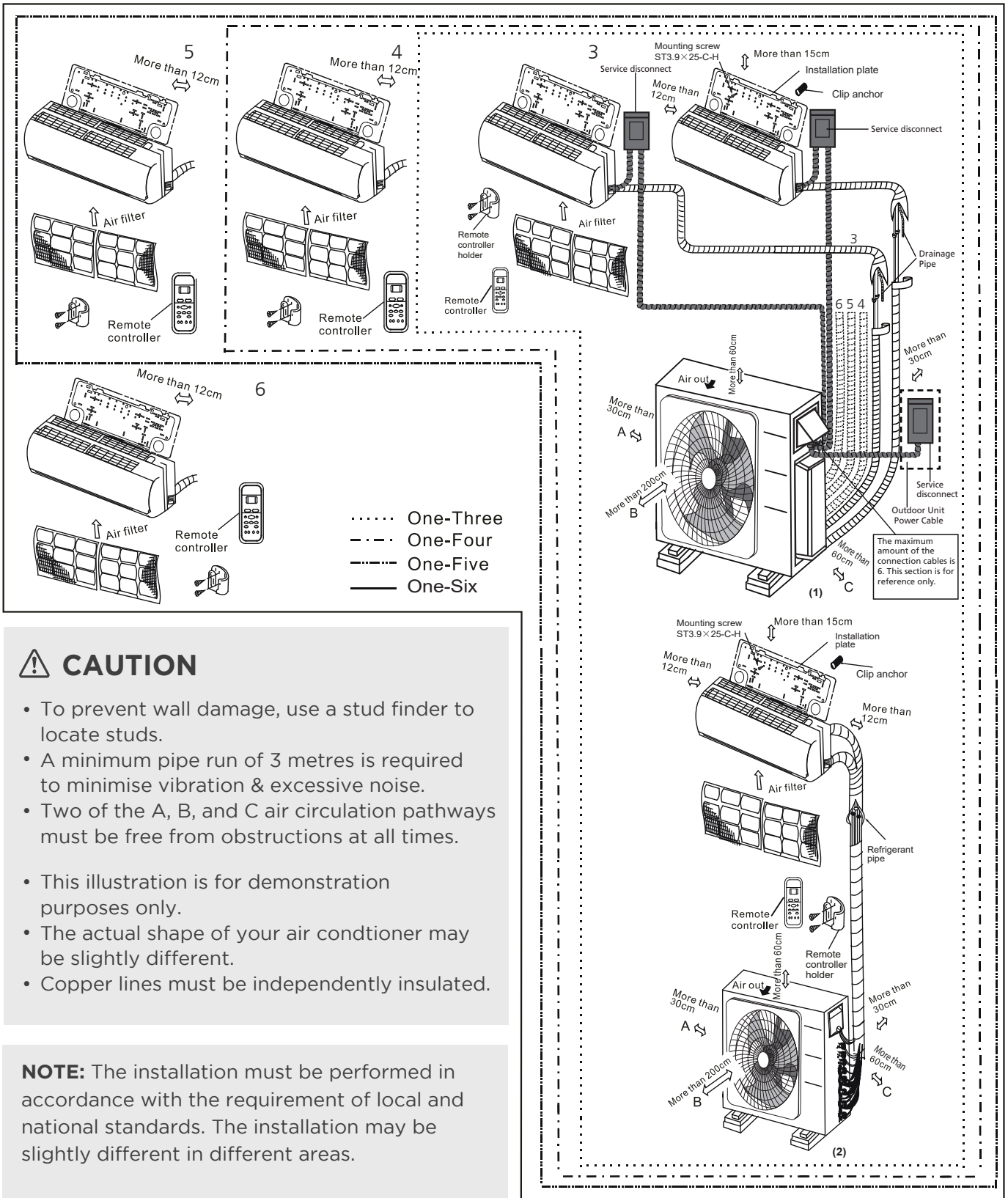

# Installation Diagram



# PRODUCTION INSTALLATION

## ACCESSORIES

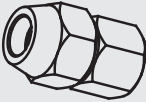
The air conditioning system comes with the following accessories. Use all of the installation parts and accessories to install the air conditioner. Improper installation may result in water leakage, electrical shock and fire, or cause the equipment to fail. The items are not included with the air conditioner must be purchased separately.

Name of Accessories	Q'ty (pc)	Shape	Name of Accessories	Q'ty (pc)	Shape
Manual	1~4		Drain joint	1	
Transfer connector (packed with the indoor or outdoor unit) NOTE: Pipe size may differ from appliance to appliance. To meet different pipe size requirements, sometimes the pipe connections need a transfer connector installed on the outdoor unit .	Optional part (one piece per indoor unit)		Seal ring (Not available for the outdoor unit with dimensions of 38.58in*38.39in*16.34in)	1	
	Optional part (1-8 pieces for outdoor unit)				

### Optional accessories

There are two types of remote controls: wired and wireless.

Select a remote controller based on customer preferences and requirements and install in an appropriate place.

Refer to catalogues and technical literature for guidance on selecting a suitable remote controller.

Name	Model	Pipe specification		Remark
		Liquid Side	Gas Side	
Connecting pipe assembly	6K/9K/12K	Ø1/4in (Ø6.35)	Ø3/8in (Ø9.52)	Parts you must purchase separately. Consult the dealer about the proper pipe size of the unit you purchased.
	18K	Ø1/4in (Ø6.35)	Ø1/2in (Ø12.7)	
	24K/30K/33K/36K	Ø3/8in (Ø9.52)	Ø5/8in (Ø15.9)	

# INSTALLATION SUMMARY

1

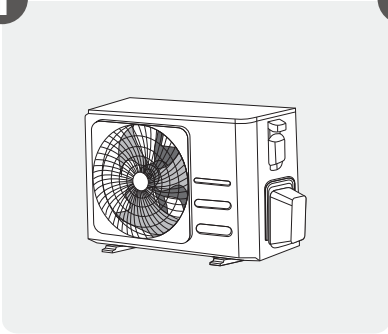

Install the outdoor unit

2

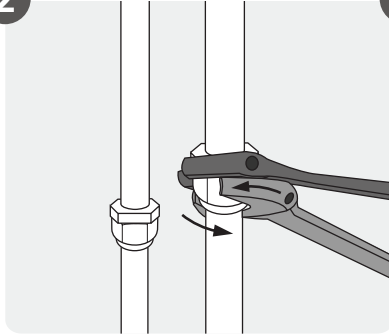

Connect the refrigerant pipes

3

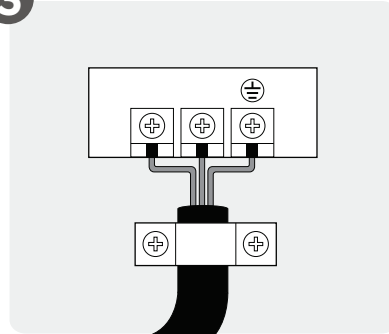

Connect the wires

5

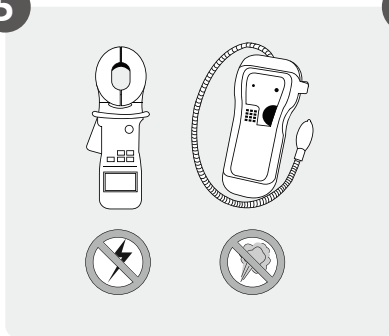

Perform a test run

4

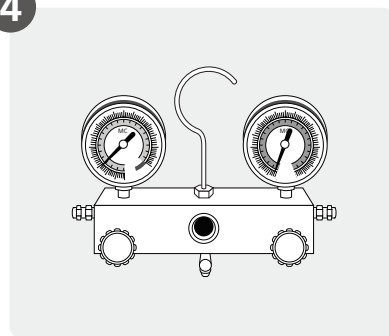

Evacuate the refrigeration system

# Install Outdoor Unit

1

## Select installation location

### NOTE: PRIOR TO INSTALLATION

Before installing the outdoor unit, you must choose an appropriate location. The following are standards that will help you choose an appropriate location for the unit.

#### Proper installation locations meet the following standards:

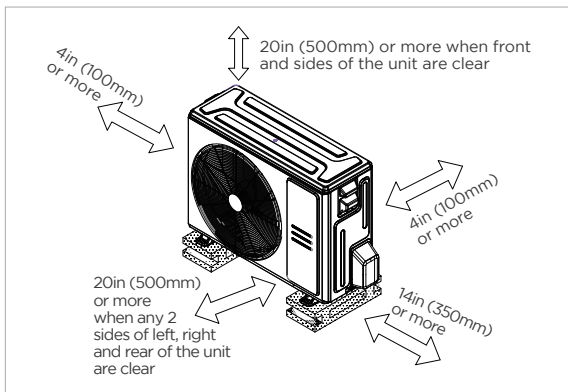

✓ Good air circulation and ventilation.



✓ Firm and solid—the location can support the unit and will not vibrate.



✓ Noise from the unit will not disturb other people.



✓ Protected from prolonged periods of direct sunlight or rain.



✓ Where snowfall is anticipated, take appropriate measures to prevent ice buildup and coil damage.

✓ Meets all spatial requirements shown in Installation Clearance Requirements above.

**NOTE** Install the unit by following local codes and regulations, there may be differ slightly between different regions.

### CAUTION:

#### SPECIAL CONSIDERATIONS FOR EXTREME WEATHER

##### If the unit is exposed to heavy wind:

Install unit so that air outlet fan is at a 90° angle to the direction of the wind. If needed, build a barrier in front of the unit to protect it from extremely heavy winds. See Figures below.

##### If the unit is frequently exposed to heavy rain or snow:

Build a shelter above the unit to protect it from the rain or snow. Be careful not to obstruct air flow around the unit.

##### If the unit is frequently exposed to salty air (seaside):

Use outdoor unit that is specially designed to resist corrosion.

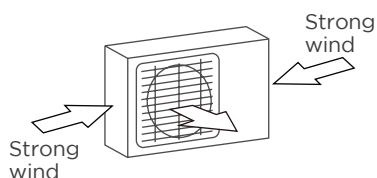

90° angle to the direction of the wind

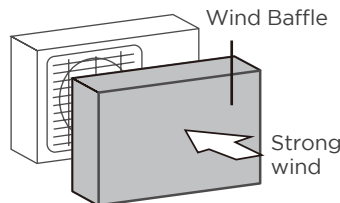

Build a wind Baffle to protect the unit

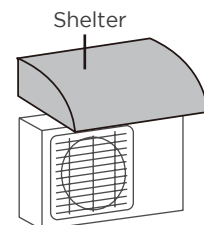

Build a shelter to protect the unit

#### DO NOT install unit in the following locations:

- ⊘ Near an obstacle that will block air inlets and outlets.
- ⊘ Near animals or plants that will be harmed by hot air discharge.
- ⊘ In a location that is exposed to large amounts of dust
- ⊘ Near a public street, crowded areas, or where noise from the unit will disturb others.
- ⊘ Near any source of combustible gas.
- ⊘ In a location exposed to an excessive amounts of salty air.

## 2

### Install drain joint (Heat pump unit only)

Before bolting the outdoor unit in place, you must install the drain joint at the bottom of the unit.

Note that there are two different types of drain joints depending on the type of outdoor unit.

**If the drain joint comes with a rubber seal (see Fig. A), do the following:**

1. Fit the rubber seal on the end of the drain joint that will connect to the outdoor unit.
2. Insert the drain joint into the hole in the base pan of the unit.
3. Rotate the drain joint 90° until it clicks in place facing the front of the unit.
4. Connect a drain hose extension (not included) to the drain joint to redirect water from the unit during heating mode.

**If the drain joint doesn't come with a rubber seal (see Fig. B), do the following:**

1. Insert the drain joint into the hole on the base pan, press firmly to ensure it is properly installed and will not become loose.
2. Connect a drain hose extension (not included) to the drain joint to redirect water from the unit during heating mode.

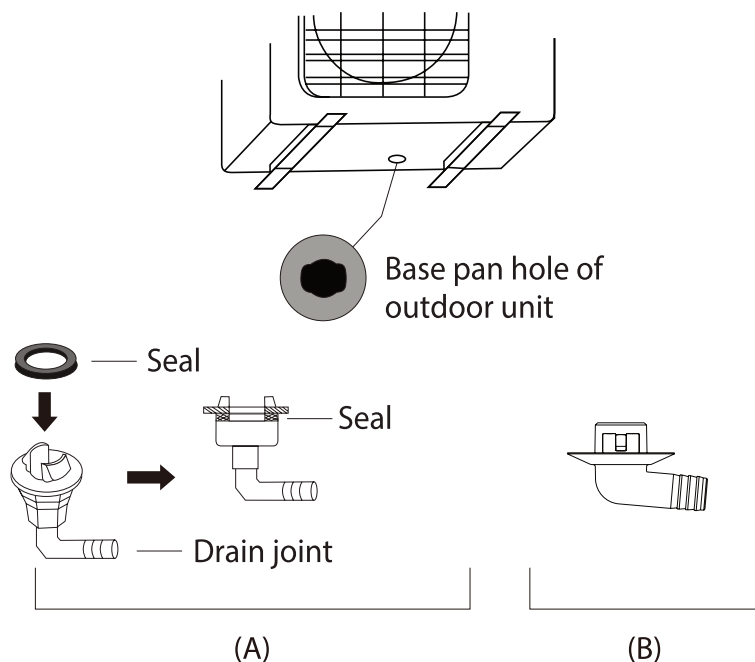

### ! IN COLD CLIMATES

In cold climates, make sure that the drain hose is as vertical as possible to ensure swift water drainage. If water drains too slowly, it can freeze in the hose and flood the unit.

### 3

## Anchor Outdoor Unit

### ⚠ WARNING

WHEN DRILLING INTO CONCRETE, EYE PROTECTION IS RECOMMENDED AT ALL TIME.

- The outdoor unit can be anchored to the ground or to a wall-mounted bracket with bolt (M10). Prepare the installation base of the unit according to the dimensions below.
- The following is a list of different outdoor unit sizes and the distance between their mounting feet. Prepare the installation base of the unit according to the dimensions below.

### Outdoor Unit Types and Specifications (Split Type Outdoor Unit)

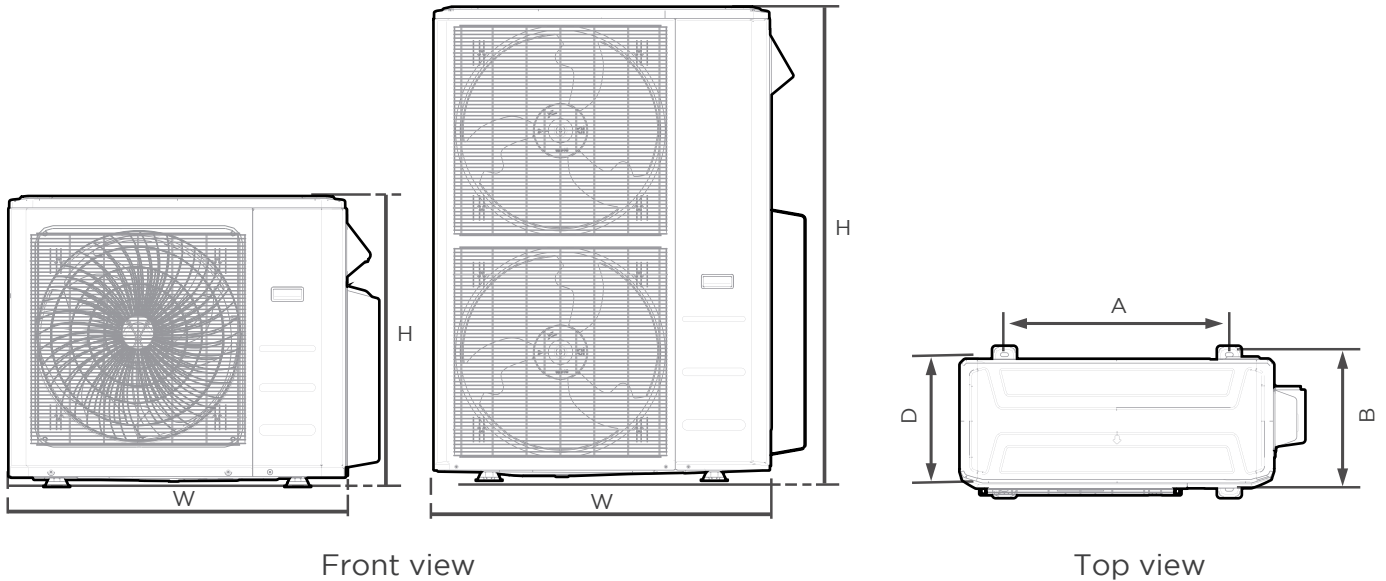

Outdoor Unit Dimensions W x H x D	Mounting Dimensions	
	Distance A	Distance B
35.0inx 26.5inx 13.5in (890mmx673mmx342mm)	26.1in (663mm)	13.9in (354mm)
37.2inx31.9inx16.14in (946mmx810mmx410mm)	26.5in (673mm)	15.87in (403mm)
38.58inX38.39inX16.34in (980mmX975mmX415mm)	24.25in (616mm)	15.63in (397mm)
37.5inx52.5inx16.34in (952mmx1333mmx415mm)	24.96in (634mm)	15.9in (404mm)

### Rows of series installation

The relations between H, A and L are as follows.

	L	A
L ≤ H	L ≤ 1/2H	9.8in (250mm) or more
	1/2H < L ≤ H	11.8in (300mm) or more
L > H	Cannot be installed	

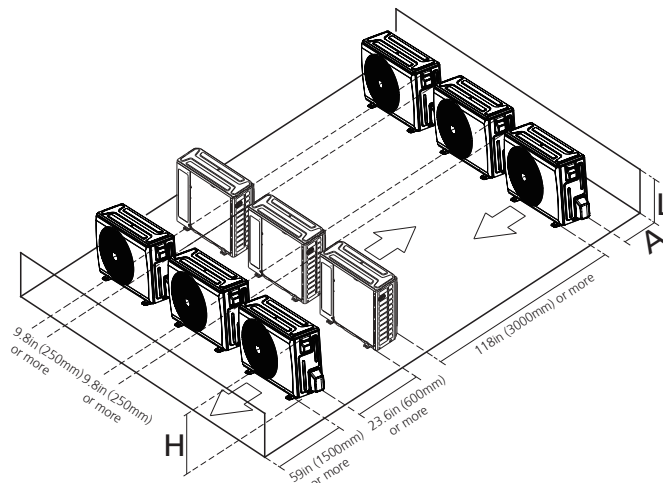

## Notes On Drilling Hole In Wall

You must drill a hole in the wall for the refrigerant piping, and the signal cable that will connect the indoor and outdoor units.

1. Determine the location of the wall hole based on the location of the outdoor unit.
2. Using a 2.5in (65mm) core drill, drill a hole in the wall.

**NOTE:** When drilling the wall hole, make sure to avoid wires, plumbing, and other sensitive components.

3. Place the protective wall cuff in the hole. This protects the edges of the hole and helps seal it when you finish the installation process.

### When Select 24K/30K/33K/36K Indoor Unit

The 24K/30K/33K/36K indoor unit can only be connected with an A system. If there are two 24K/30K/33K/36K indoor units, they can be connected with A and B systems.

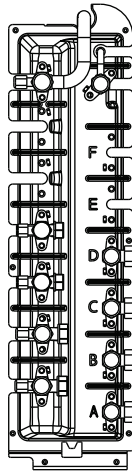

# REFRIGERANT PIPING CONNECTION

## NOTE :

NOTE: For quick-connect models, please refer to the internal machine manual for the installation method of the connecting pipe. The external machine manual does not repeat the instructions.

When connecting refrigerant piping, **DO NOT** let substances or gases other than the specified refrigerant enter the unit. The presence of other gases or substances will lower the unit's capacity, and can cause abnormally high pressure in the refrigeration cycle. This can cause explosion and injury.

## Connection Instructions—Refrigerant Piping

### CAUTION

- The branching pipe must be installed horizontally. An angle of more than 10° may cause malfunction.
- **DO NOT** install the connecting pipe until both indoor and outdoor units have been installed.
- Insulate both the gas and liquid piping to prevent condensation.

### Step 1: Cut pipes

When preparing refrigerant pipes, take extra care to cut and flare them properly. This will ensure efficient operation and minimize the need for future maintenance.

- Measure the distance between the indoor and outdoor units.
- Using a pipe cutter, cut the pipe a little longer than the measured distance.
- Make sure that the pipe is cut at a perfect 90° angle.

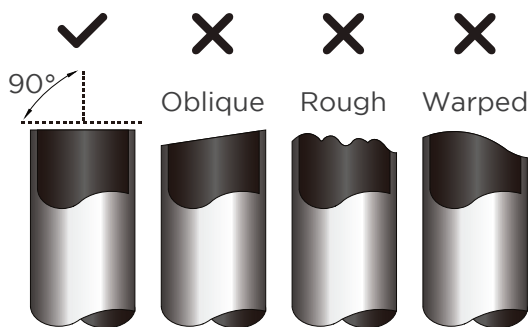

### DO NOT DEFORM PIPE WHILE CUTTING

Be extra careful not to damage, dent, or deform the pipe while cutting. This will drastically reduce the heating

### Step 2: Remove burrs

Burrs can affect the air-tight seal of refrigerant piping connection. They must be completely removed.

- Hold the pipe at a downward angle to prevent burrs from falling into the pipe.
- Using a reamer or deburring tool, remove all burrs from the cut section of the pipe.

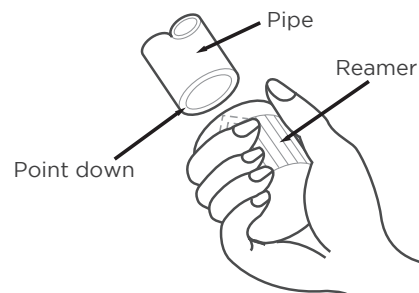

### Step 3: Flare pipe ends

Proper flaring is essential to achieve an airtight seal.

- After removing burrs from cut pipe, seal the ends with PVC tape to prevent foreign materials from entering the pipe.
- Sheath the pipe with insulating material.
- Place flare nuts on both ends of pipe. Make sure they are facing in the right direction, because you can't put them on or change their direction after flaring.

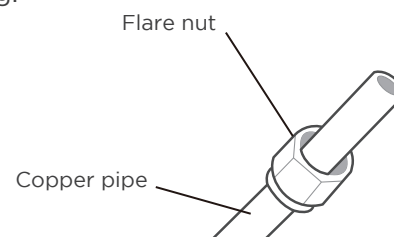

- Remove PVC tape from ends of pipe when ready to perform flaring work.

- Clamp flare from on the end of the pipe. The end of the pipe must extend beyond the flare form.

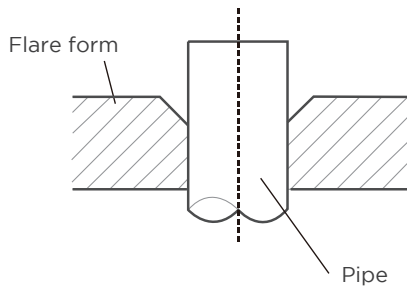

- Place flaring tool onto the form.
- Turn the handle of the flaring tool clockwise until the pipe is fully flared.

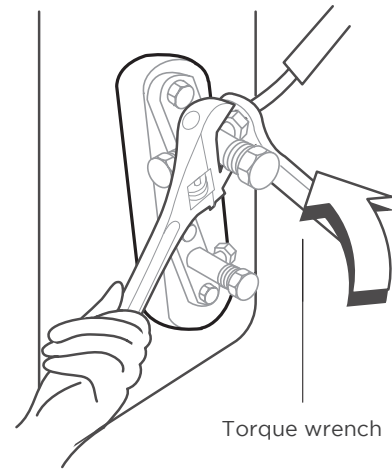

### PIPING EXTENSION BEYOND FLARE FORM

Pipe gauge	Tightening torque	Flare dimension (A)	Flare shape
Ø1/4in (Ø6.35mm)	18~20N·m (180~200kgf·cm)	0.33~0.34in (8.4~8.7mm)	
Ø3/8in (Ø9.52mm)	32~39N·m (320~390kgf·cm)	0.52~0.53in (13.2~13.5mm)	
Ø1/2in (Ø12.7mm)	49~59N·m (490~590kgf·cm)	0.64~0.65in (16.2~16.5mm)	
Ø5/8in (Ø16mm)	57~71N·m (570~710kgf·cm)	0.76~0.78in (19.2~19.7mm)	

- Remove the flaring tool and flare form, then inspect the end of the pipe for cracks and even flaring.

### Step 4: Connect pipes

Connect the copper pipes to the indoor unit first, then connect it to the outdoor unit. You should first connect the low-pressure pipe, then the high pressure pipe.

- When connecting the flare nuts, apply a thin coat of refrigeration oil to the flared ends of the pipes.
- Align the center of the two pipes that you will connect.

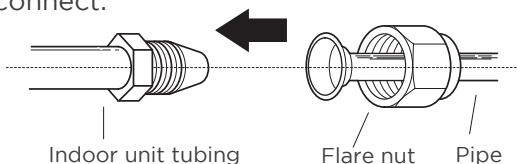

- Tighten the flare nut snugly by hand.
- Using a wrench, grip the nut on the unit tubing.
- While firmly gripping the nut, use a torque wrench to tighten the flare nut according to the torque values in above table.

### NOTICE

Use both a spanner and a torque wrench when connecting or disconnecting pipes to/from the unit.

### CAUTION

Ensure to wrap insulation around the piping. Direct contact with the bare piping may result in burns or frostbite.

- Make sure the pipe is properly connected. Over tightening may damage the bell mouth and under tightening may lead to leakage.

### NOTICE MINIMUM BEND RADIUS

Carefully bend the tubing in the middle according to the diagram below.

- **DO NOT** bend the tubing more than 90° or more than 3 times.

Use appropriate tool

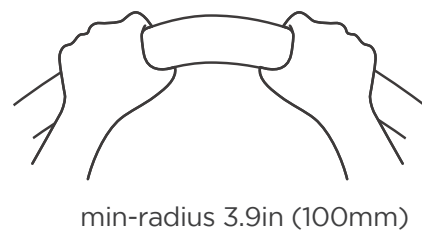

- After connecting the copper pipes to the indoor unit, wrap the power cable, signal cable and the piping together with binding tape.

### NOTICE

**DO NOT** intertwine signal cable with other wires. While bundling these items together. **DO NOT** intertwine or cross the signal cable with any other wiring.

# WIRING PRECAUTIONS

## ⚠ WARNING

BEFORE PERFORMING ANY ELECTRICAL WORK, READ THESE WARNINGS.

- All wiring must comply with local and national electrical codes, regulations and must be installed by a licensed electrician.
- All electrical connections must be made according to the Electrical Connection Diagram located on the panels of the indoor and outdoor units.
- If there is a serious safety issue with the power supply, stop work immediately. Explain your reasoning to the client, and refuse to install the unit until the safety issue is properly resolved.
- Power voltage should be within 90-110% of rated voltage. Insufficient power supply can cause malfunction, electrical shock, or fire.
- Installation of an external surge suppressor at the outdoor disconnect is recommended.
- If connecting power to fixed wiring, a switch or circuit breaker that disconnects all poles and has a contact separation of at least 1/8in (3mm) must be incorporated in the fixed wiring. The qualified technician must use an approved circuit breaker or switch.
- Only connect the unit to an individual branch circuit. Do not connect another appliance to that outlet.
- Make sure to properly ground the air conditioner.
- Every wire must be firmly connected. Loose wiring can cause the terminal to overheat, resulting in product malfunction and possible fire.
- Do not let wires touch or rest against refrigerant tubing, the compressor, or any moving parts within the unit.
- If the unit has an auxiliary electric heater, it must be installed at least 40in (1m) away from any combustible materials.
- To avoid getting an electric shock, never touch the electrical components soon after the power supply has been turned off. After turning off the power, always wait 10 minutes or more before you touch the electrical components.
- Make sure that you do not cross your electrical wiring with your signal wiring. This may cause distortion, interference or possibly damage to circuit boards.
- No other equipment should be connected to the same power circuit.
- Connect the outdoor wires before connecting the indoor wires.

## ⚠ WARNING

BEFORE PERFORMING ANY ELECTRICAL OR WIRING WORK, TURN OFF THE MAIN POWER TO THE SYSTEM.

## NOTE ON SERVICE DISCONNECT

When the maximum current of the air conditioner is more than 16A, a service disconnect or leakage protection switch with protective device shall be used (purchased separately). When the maximum current of the air conditioner is less than 16A, the power cord of air conditioner shall be equipped with plug (purchased separately). In North America, the appliance should be wired according to NEC and CEC requirements.

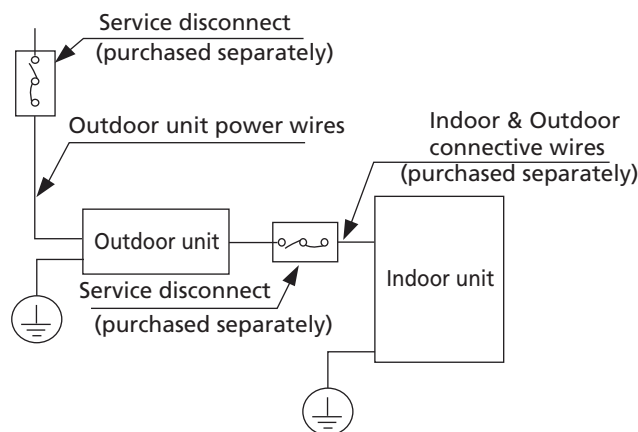

**NOTE:** The cognographs are for explanation purpose only. Your machine may be slightly different. The actual shape shall prevail. Service disconnect shall select as required by local, regional, and national codes.

# OUTDOOR UNIT WIRING

## **⚠ WARNING**

Before performing any electrical or wiring work, turn off the main power to the system.

1. Prepare the cable for connection
  - a. You must first choose the right cable size.

**NOTE:** In North America, choose the cable type according to the local electrical codes and regulations.

### CHOOSE THE RIGHT CABLE SIZE

The size of the power supply cable, signal cable, fuse, and switch needed is determined by the maximum current of the unit. The maximum current is indicated on the nameplate located on the side panel of the unit. Refer to this nameplate to choose the right cable, fuse, or switch.

**NOTE:** In North America, please choose the right cable size according to the Minimum Circuit Ampacity indicated on the nameplate of the unit.

- b. Using wire strippers, strip the rubber jacket from both ends of the signal cable to reveal approximately 5.9in (150mm) of wire.
- c. Strip the insulation from the ends.
- d. Using a wire crimper, crimp u-lugs on the ends.

**NOTE:** When connecting the wires, strictly follow the wiring diagram found inside the electrical box cover.

2. Remove the electric cover of the outdoor unit. If there is no cover on the outdoor unit, take off the bolts from the maintenance board and remove the protection board.

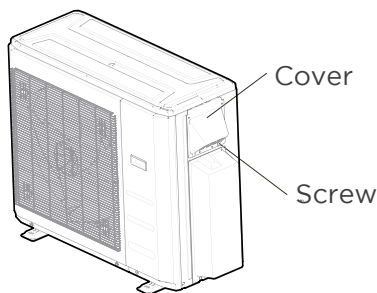

3. Connect the u-lugs to the terminals  
Match the wire colors/labels with the labels on the terminal block. Firmly screw the u-lug of each wire to its corresponding terminal.

4. Clamp down the cable with the cable clamp.
5. Insulate unused wires with electrical tape. Keep them away from any electrical or metal parts.
6. Reinstall the cover of the electric control box.

### Wiring Figure

## **⚠ CAUTION**

Connect the connective cables to the terminals, as identified, with their matching numbers on the terminal block of the indoor and outdoor units. For example, Terminal L1 (A) of the outdoor unit must connect with terminal L1/1 on the indoor unit. The outdoor unit can match different types of indoor unit, the numbers on the terminal block of the indoor unit may be slightly different. Please pay special attention while connecting the wire.

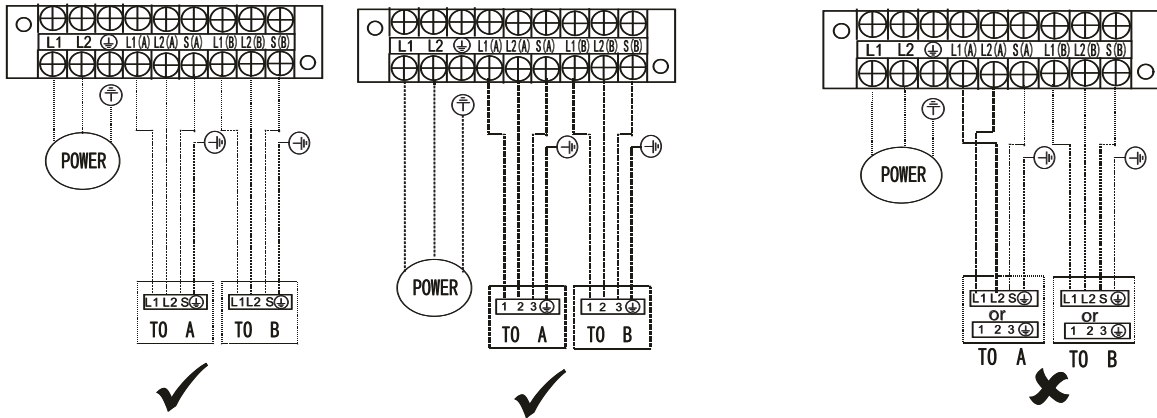

**NOTE:** For quick-connector models, please refer to <<USER MANUAL>> packed with the indoor unit. Refer to the following figures if end-users wish to perform their own wiring. Run the main power cord through the lower line-outlet of the cord clamp. ---- This symbol indicates field wiring.

**One-three models:**

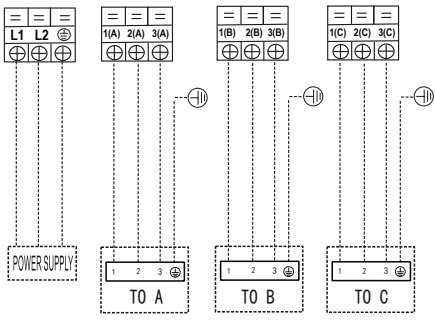

Model A

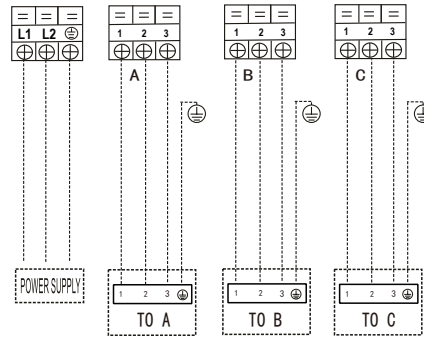

Model B

**One-four models:**

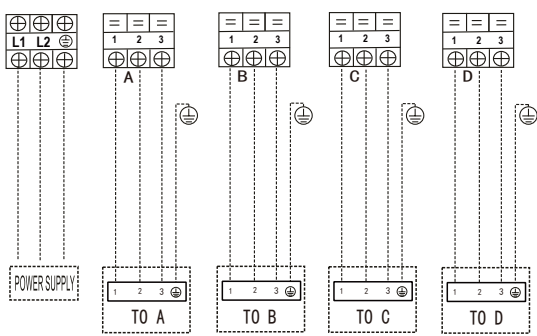

Model A

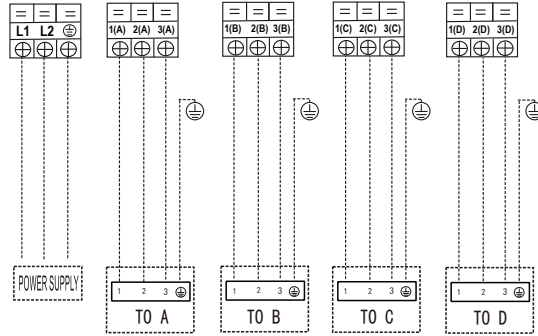

Model B

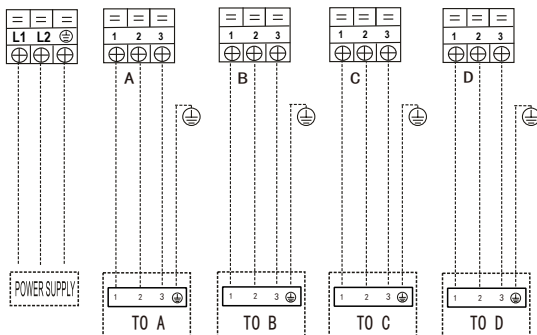

Model C

## One-five models:

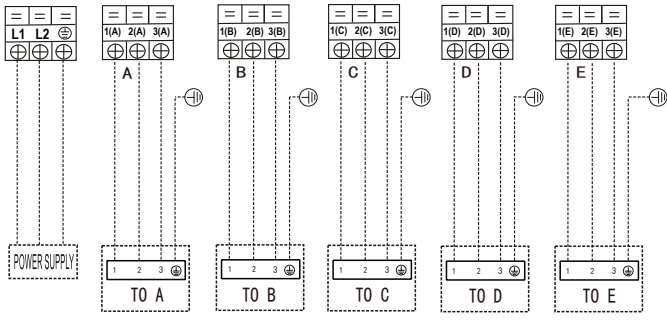

Model A

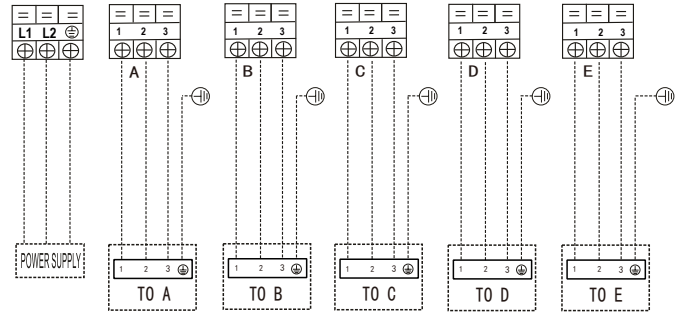

Model B

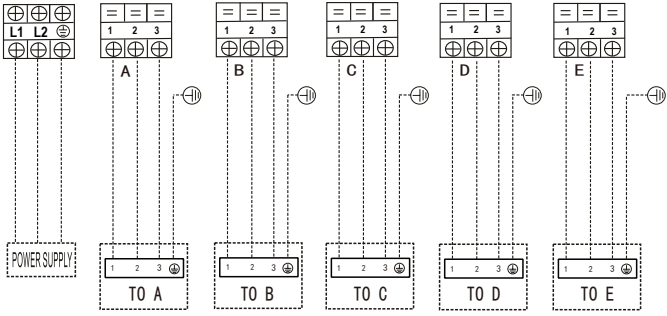

Model C

## One-six models:

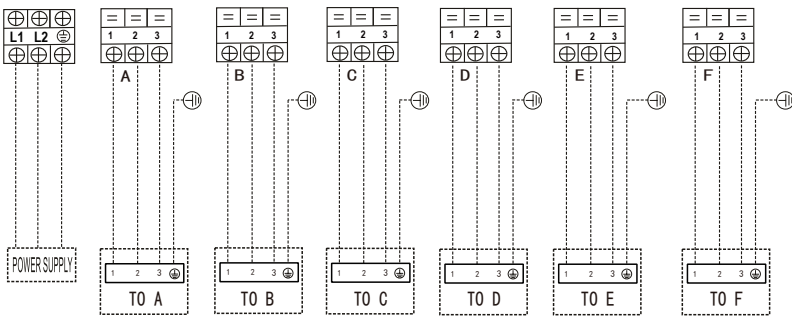

Model A

## CAUTION

After confirmation of the above conditions, follow these guidelines when performing wiring:

- Always have an individual power circuit specifically for the air conditioner. Always follow the circuit diagram posted on the inside of the control cover.
- Screws fastening the wiring in the casing of electrical fittings may come loose during transportation. Because loose screws may cause wire burn-out, check that the screws are tightly fastened.
- Check the specifications for the power source.
- Confirm that electrical capacity is sufficient.
- Confirm that starting voltage is maintained at more than 90 percent of the rated voltage marked on the name plate.
- Confirm that the cable thickness is as specified in the power source specifications.
- Always install an earth leakage circuit breaker in wet or moist areas.
- The following can be caused by a drop in voltage: vibration of a magnetic switch, damaging the contact point, broken fuses, and disturbance of normal functioning.
- Disconnection from a power supply must be incorporated into the fixed wiring. It must have an air gap contact separation of at least 3mm in each active (phase) conductors.
- Before accessing terminals, all supply circuits must be disconnected.

## NOTE:

To satisfy the EMC compulsory regulations, which is required by the international standard CISPR 14-1:2005/A2:2011 in specific countries or districts, please make sure you apply the correct magnetic rings on your equipment according to the wiring diagram that adhere to your equipment.

Please contact your distributor or installer to get further information and purchase magnetic rings (The supplier of magnetic ring is TDK (model ZCAT3035-1330) or similar).

# AIR EVACUATION

## NOTICE

When opening valve stems, turn the hexagonal wrench until it hits against the stopper. Do not try to force the valve to open further.

## Preparations and precautions

Air and foreign matter in the refrigerant circuit can cause abnormal rises in pressure, which can damage the air conditioner, reduce its efficiency, and cause injury. Use a vacuum pump and manifold gauge to evacuate the refrigerant circuit, removing any non-condensable gas and moisture from the system. Evacuation should be performed upon initial installation and when unit is relocated.

### BEFORE PERFORMING EVACUATION

- ✓ Check to make sure the connective pipes between the indoor and outdoor units are connected properly .
- ✓ Check to make sure all wiring is connected properly.

## Evacuation Instructions

1. You can choose to evacuate all indoor unit systems directly through the main valve, which requires opening all branch valves of connected indoor units, or evacuate each indoor unit system sequentially through the corresponding branch valve, which requires opening the main valve.
2. Connect the charge hose of the manifold gauge to service port on the outdoor unit's low pressure valve.
3. Connect another charge hose from the manifold gauge to the vacuum pump.
4. Open the Low Pressure side of the manifold gauge. Keep the High Pressure side closed.

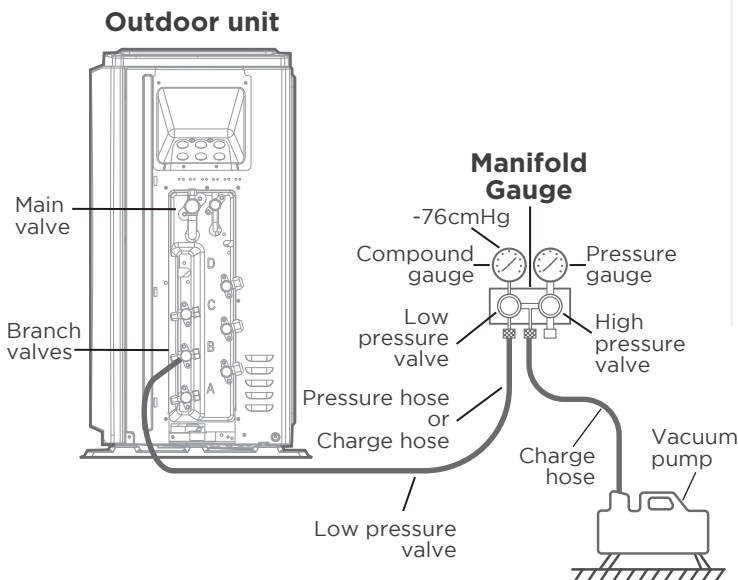

5. Turn on the vacuum pump to evacuate the system.
6. Run the vacuum for at least 15 minutes when choosing evacuation through each branch valves , or until the Compound Meter reads -76cmHG (-105Pa). When choosing evacuation through the main valve, run the vacuum for at least 30 minutes.
7. Close the Low Pressure side of the manifold gauge, and turn off the vacuum pump.
8. Wait for 5 minutes, then check that there has been no change in system pressure.
9. If there is a change in system pressure, refer to Gas Leak Check section for information on how to check for leaks. If there is no change in system pressure, unscrew the cap from the packed valve (high pressure valve).
10. Insert hexagonal wrench into the packed valve (high pressure valve) and open the valve by turning the wrench in a 1/4 counterclockwise turn. Listen for gas to exit the system, then close the valve after 5 seconds.
11. Watch the Pressure Gauge for one minute to make sure that there is no change in pressure. The Pressure Gauge should read slightly higher than atmospheric pressure.
12. Remove the charge hose from the service port.

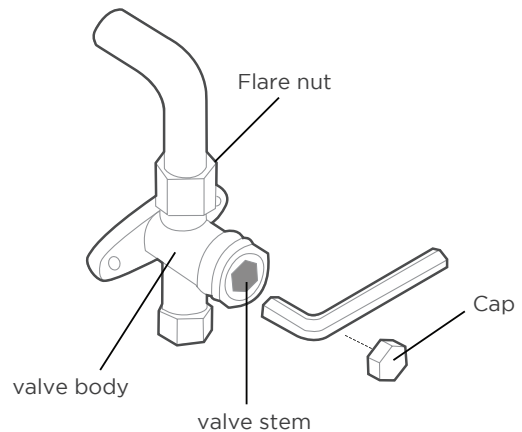

13. Using hexagonal wrench, fully open both the high pressure and low pressure valves.
14. Tighten valve caps on all three valves (service port, high pressure, low pressure) by hand. You may tighten it further using a torque wrench if needed.

## Safety And Leakage Check

### Electrical safety check

Perform the electrical safety check after completing installation. Cover the following areas:

1. Insulated resistance  
The insulated resistance must be more than  $2M\Omega$ .
2. Grounding work  
After finishing grounding work, measure the grounding resistance by visual detection and using the grounding resistance tester. Make sure the grounding resistance is less than  $4\Omega$ .
3. Electrical leakage check (performing during test while unit is on)  
During a test operation after completed installation, the use the electro probe and multimeter to perform an electrical leakage check. Turn off the unit immediately if leakage happens. Try and evaluate different solutions until the unit operates properly.

### Gas leak check

1. Soap water method:  
Apply a soap-water solution or a liquid neutral detergent on the indoor unit connection or outdoor unit connections with a soft brush to check for leakage of the connecting points of the piping. If bubbles emerge, the pipes are experiencing leakage.
2. Leak detector  
Use the leak detector to check for leakage.

**NOTE:** The illustration is for example purposes only. The actual order of A, B, C, D, E and F on the machine may be slightly different from the unit you purchased but the general shape will remain the same.

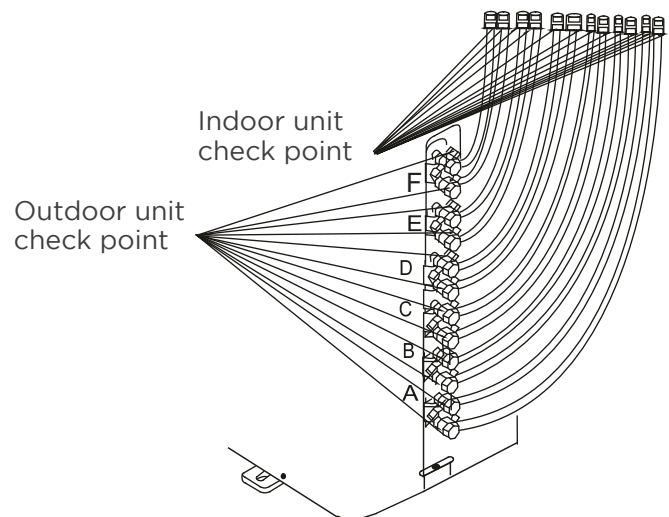

A, B,C,D are points for one-four type.  
A, B,C,D, and E are points for the one-five type.  
A,B,C,D,E,and F are points for the one-six type.

## Note On Adding Refrigerant

### CAUTION

- Refrigerant charging must be performed after wiring, vacuuming, and the leak testing.
- **DO NOT** exceed the maximum allowable quantity of refrigerant or overcharge the system. Doing so can damage the unit or impact it's functioning.
- Charging with unsuitable substances may cause explosions or accidents. Ensure that the appropriate refrigerant is used.
- Refrigerant containers must be opened slowly. Always use protective gear when charging the system.
- **DO NOT** mix refrigerants types.

Depending on the length of connective piping or the pressure of the evacuated system, you may need to add refrigerant. Refer to table below for refrigerant amounts to be added:

### ADDITIONAL REFRIGERANT PER PIPE LENGTH

Connective Pipe Length(m)	Air Purging Method	Additional Refrigerant	
<Standard pipe length*N	Vacuum Pump	N/A	
>Standard pipe length*N	Vacuum Pump	Liquid Side: Ø 1/4in (Ø 6.35) R454B (Total pipe length - standard length*N) x15g/m (Total pipe length - standard length*N) x0.16oz/ft	Liquid Side: Ø 3/8in (Ø 9.52) R454B (Total pipe length - standard length*N) x30g/m (Total pipe length - standard length*N) x0.32oz/ft

### NOTE:

- The standard pipe length for each indoor unit is 24.6ft/7.5m.
- N=3 for one-three models, N=4 for one-four models, N=5 for one-five models, N=6 for one-six models.

# TEST RUN

## CAUTION

Failure to perform the test run may result in unit damage, property damage, or personal injury.

### Before Test Run

A test run must be performed after the entire system has been completely installed. Confirm the following points before performing the test:

- a) The indoor and outdoor units are properly installed.
  - b) Piping and wiring are properly connected.
  - c) No obstacles near the inlet and outlet of the unit that might cause poor performance or product malfunction.
  - d) The refrigeration system does not leak.
  - e) Drainage system is unimpeded and draining to a safe location.
  - f) The heating insulation is properly installed.
  - g) The grounding wires are properly connected.
  - h) Length of the piping and additional refrigerant stow capacity have been recorded.
  - i) The power voltage is the correct voltage for the air conditioner.
- f. Check to see that the drainage system is unimpeded and draining smoothly.
  - g. Ensure there is no vibration or abnormal noise during operation.
5. For the Outdoor Unit
    - a. Check to see if the refrigeration system is leaking.
    - b. Make sure there is no vibration or abnormal noise during operation.
    - c. Ensure the wind, noise, and water generated by the unit do not disturb your neighbors or pose a safety hazard.

**NOTE:** If the unit malfunctions or does not operate according to your expectations, please refer to the Troubleshooting section of the Owner's Manual before calling customer service.

### Test Run Instructions

1. Open both the liquid and gas stop valves.
2. Turn on the main power switch and allow the unit to warm up.
3. Set the air conditioner to COOL mode.
4. For the Indoor Unit
  - a. Ensure the remote control and its buttons work properly.
  - b. Ensure the louvers move properly and can be changed using the remote control.
  - c. Double check to see if the room temperature is being registered correctly.
  - d. Ensure the indicators on the remote control and the display panel on the indoor unit work properly.
  - e. Ensure the manual buttons on the indoor unit works properly.

# FUNCTION OF AUTOMATIC WIRING/PIPING CORRECTION

## Automatic Wiring/Piping Correction Function

More recent models now feature automatic correction of wiring/piping errors. Press the "check switch" on the outdoor unit PCB board for 5 seconds until the LED displays "CE", indicating that this function is working, approximately 5-10 minutes after the switch is pressed, the "CE" disappears, meaning that the wiring/piping error is corrected and all wiring/piping is properly connected.

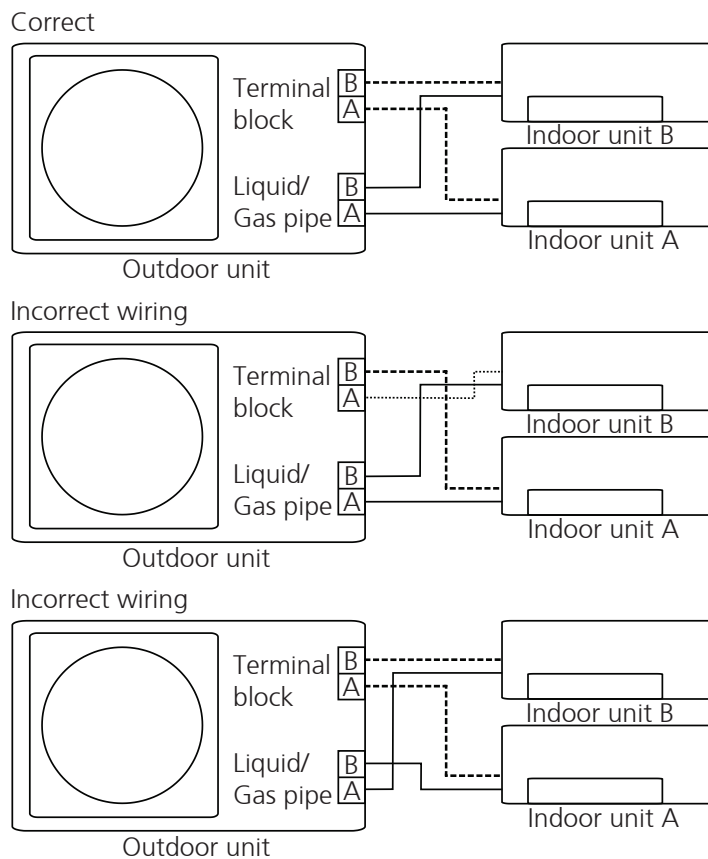
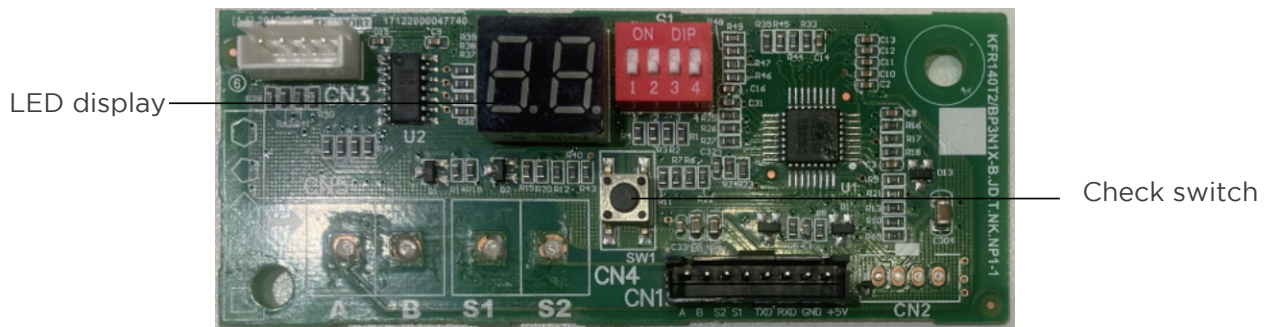

## How To Activate This Function

1. Check that outside temperature is above 5°C.  
(This function does not work when outside temperature is not above 5°C)
2. Check that the stop valves of the liquid pipe and gas pipe are open.
3. Turn on the breaker and wait at least 2 minutes.
4. Press the check switch on the outdoor PCB board unit LED display "CE".

# OPERATION INSTRUCTIONS

## Operating Conditions

When your air conditioner is used outside of the following temperature ranges, certain safety protection features may activate and cause the unit to disable.

	COOL Mode	HEAT Mode	DRY Mode
Room Temp.	16°C~32°C (60°F~90°F)	0°C~30°C (32°F~86°F)	10°C~32°C (50°F~90°F)
Outdoor Temp.	-25°C~50°C (-13°F~122°F)	-25°C~24°C (-13°F~75°F)	0°C~50°C (32°F~122°F)
	-30°C~50°C (-22°F~122°F) For Hyper Heat models	-30°C~24°C (-22°F~75°F) For Hyper Heat models	

### FOR OUTDOOR UNITS WITH AUXILIARY ELECTRIC HEATER

When outside temperature is below 0°C (32°F), we strongly recommend keeping the unit plugged in at all time to ensure smooth ongoing performance.

**NOTE:** Room relative humidity less than 80%. If the air conditioner operates in excess of this figure, the surface of the air conditioner may attract condensation. Please sets the vertical air flow louver to its maximum angle (vertically to the floor), and set HIGH fan mode.

#### To further optimize the performance of your unit, do the following:

- Keep doors and windows closed.
- Limit energy usage by using TIMER ON and TIMER OFF functions.
- Do not block air inlets or outlets.
- Regularly inspect and clean air filters.

## Features

### Compressor protection

- The compressor cannot restart for 3 minutes after it stops.

### Anti-cold air

- The unit is designed not to blow cold air on HEAT mode, when the indoor heat exchanger is in one of the following three situations and the set temperature has not been reached.
  - A) When heating has just started.
  - B) During defrosting.
  - C) Low temperature heating.
- The indoor or outdoor fan stop running when defrosting (Cooling and heating models only).

### Defrosting

- Frost may be generated on the outdoor unit during a heat cycle when outdoor temperature is low and humidity is high resulting in lower heating efficiency in the air conditioner.
- Under these conditions, the air conditioner will stop heating operations and start defrosting automatically.
- The time to defrost may vary from 4 to 10 minutes, depending the outdoor temperature and the amount of frost buildup on the outdoor unit.

### Auto-Restart

In case of power failure, the system will immediately stop. When power returns, the Operation light on the indoor unit will flash. To restart the unit, press the **ON/OFF** button on the remote control. If the system has an auto restart function, the unit will restart using the same settings.

### The air conditioner turns to FAN ONLY mode from COOL or HEAT mode.

When the indoor temperature reaches the set temperature setting, the compressor will stop automatically, and the air conditioner turns to FAN only mode. The compressor will start again when the indoor temperature rises on COOL mode or falls on HEAT mode to the set point. Droplets of water may form on the surface of the indoor unit when cooling occurs in relatively high humidity (defined as higher than 80%). Adjust the horizontal louver to the maximum air outlet position and select HIGH fan speed.

### White mist emerging from the indoor unit

- A white mist may be generated due to a large temperature difference between air inlet and air outlet on COOL mode in places with high relative humidity.
- A white mist may be generated due to moisture created in the defrosting process when the air conditioner restarts in HEAT mode operation after defrosting.

### Noise coming from the air conditioner

- You may hear a low hissing sound when the compressor is running or has just stopped running. This sound is the sound of the refrigerant flowing or coming to a stop.
- You may also hear a low “squeaking” sound when the compressor is running or has just stopped running. This is caused by tempera heat expansion and cold contraction of the plastic parts in the unit when the temperature is changing.
- A noise may be heard due to the louver restoring itself to its original position when power is first turned on.

### Dust blowing out from the indoor unit.

This is happening when the air conditioner has not been used for a long time or during its first use.

### Smell emitting from the indoor unit.

This is caused by the indoor unit giving off smells permeated from building materials, furniture, or smoke.

### Heating mode

The air conditioner draws in heat from the outdoor unit and releases it via the indoor unit during heating. When the outdoor temperature falls, heat drawn in by the air conditioner decreases accordingly. At the same time, heat loading of the air conditioner increases due to larger difference between indoor and outdoor temperature. If a comfortable temperature cannot be achieved with the air conditioner alone, it is recommended that you use a supplementary heating device.

Lightning or a car wireless telephone operating nearby may cause the unit to malfunction. Disconnect the unit from its power source and then re-connect the unit with the power source again. Push the ON/OFF button on the remote controller to restart operations.

• **Outdoor Unit Reverse Fan Operation function:**

This feature helps keep the outdoor coil cleaner and may extend the duration between regular maintenance intervals depending on local conditions. When the unit is turned off, a 10 second delay occurs then the outdoor fan runs in reverse rotation for 70 seconds to blow off loose accumulated dust and debris.

• **Thermal-off in heat mode:**

When one indoor temperature reaches its temperature setting in heat mode but the compressor is still running, in order to prevent excessive heating, the FAN will run 1 min ON and 8 min OFF in cycle. The indoor temperature detection of this unit may be inaccurate because of thermal accumulation, causing difficulties in exiting thermal-off. It is recommended to activate the “follow me” function on the remote controller.

## Energy Saving Tips

- **DO NOT** set the unit to excessive temperature levels.
- While cooling, close the curtains to avoid direct sunlight.
- Doors and windows should be kept closed to keep cool or warm air in the room.
- **DO NOT** place objects near the air inlet and outlet of the unit. This will reduce the efficiency of the unit.
- Set a timer and use the built-in SLEEP/ECONOMY mode if applicable.
- If you don't plan to use the unit for a long time, remove the batteries from the remote control.
- Clean the air filter every two weeks. A dirty filter can reduce cooling or heating efficiency.
- Adjust louvers properly and avoid direct airflow.

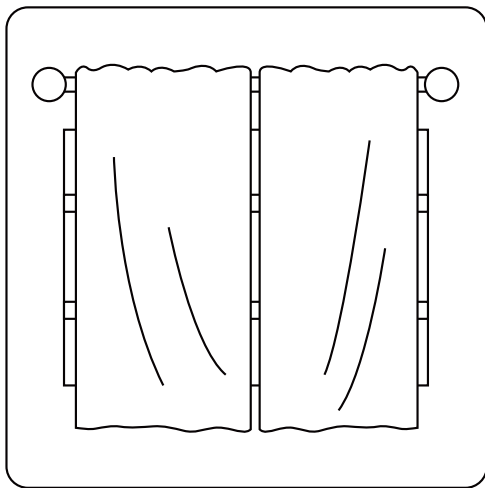

**Closing curtains during heating also helps keep the heat in**

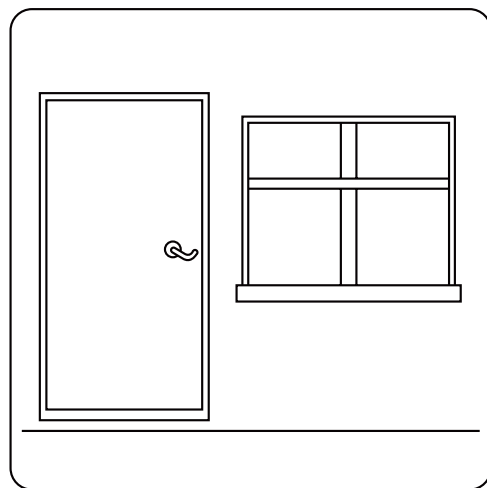

**Doors and windows should be kept closed**

# MANUAL OPERATIONS AND MAINTENANCE

## Operation mode selection

While two or more indoor units are simultaneously operating, make sure the modes do not conflict with each other. The heat mode claims precedence over all other modes. If the unit initially started to operate in HEAT mode, the other units can operate in HEAT mode only. For example: If the unit initially started operates under COOL (or FAN) mode, the other units can operate under any mode except HEAT. If one of the units selects HEAT mode, the other operating units will stop operation and display "--" (for units with display window only) or the auto and operation indication light will flash rapidly, the defrost indication light will turn off, and the timer indication light will remain on (for units without a display window). Alternatively, the defrost and alarm indication light (if applicable) will light up, or the operation indication light will flash rapidly, and the timer indication light will turn off ( for the floor and standing type).

## Maintenance

If you plan to leave the unit idle for a long time, perform the following tasks:

1. Clean the indoor unit and air filter.
2. Select FAN ONLY mode and let the indoor fan run for a time to dry the inside of the unit.
3. Disconnect the power supply and remove the battery from the remote control.
4. Check components of the outdoor unit periodically. Contact a local dealer or a customer service center if the unit requires servicing.

**NOTE:** Before you clean the air conditioner, be sure to switch off the unit and disconnect the power supply plug.

## Optimal operation

To achieve optimal performance, please note the following:

- Adjust the direction of the air flow so that it is not blowing directly on people.
- Adjust the temperature to achieve the highest possible level of comfort. Do not adjust the unit to excessive temperature levels.
- Close doors and windows in COOL mode or HEAT mode.
- Use the TIMER ON button on the remote controller to select a time you want to start your air conditioner.
- Do not place any object near the air inlet or air outlet, as the efficiency of the air conditioner may be reduced and the air conditioner may stop running.
- Clean the air filter periodically, otherwise cooling or heating performance may be reduced.
- Do not operate unit with horizontal louvre in closed position.

### Suggestion:

**For units that feature an electric heater, when the outside ambient temperature is below 0°C (32°F), it is strongly recommended that you to keep the machine plugged in so as to guarantee smooth operation.**

## When the air conditioner is to be used again:

- Use a dry cloth to wipe off the dust accumulated on the rear air intake grille in order to avoid the dust being dispersed from the indoor unit.
- Check that the wiring is not broken off or disconnected.
- Check that the air filter is installed.
- Check if the air outlet or inlet is blocked after the air conditioner has not been used for a long time.

# TROUBLESHOOTING

## CAUTION

If any of the following conditions occurs, turn off your unit immediately!

- The power cord is damaged or abnormally warm
- You smell a burning odor
- The unit emits loud or abnormal sounds
- A power fuse blows or the circuit breaker frequently trips
- Water or other objects fall into or out of the unit

**DO NOT ATTEMPT TO FIX THESE YOURSELF! CONTACT AN AUTHORIZED SERVICE PROVIDER IMMEDIATELY.**

## Common Issues

The following problems are not a malfunction and in most situations will not require repairs.

Issue	Possible Causes
<b>Unit does not turn on when pressing ON/OFF button</b>	The Unit has a 3-minute protection feature that prevents the unit from overloading. The unit cannot be restarted within three minutes of being turned off.
	Cooling and Heating Models: If the Operation light and PRE-DEF (Pre-heating/Defrost) indicators are lit up, the outdoor temperature is too cold and the unit's anti-cold wind is activated in order to defrost the unit.
	In Cooling-only Models: If the Fan Only" indicator is lit up, the outdoor temperature is too cold and the unit's anti-freeze protection is activated in order to defrost the unit.
<b>The unit changes from COOL/HEAT mode to FAN mode</b>	The unit may change its setting to prevent frost from forming on the unit. Once the temperature increases, the unit will start operating in the previously selected mode again.
	The set temperature has been reached, at which point the unit turns off the compressor. The unit will continue operating when the temperature fluctuates again.
<b>The indoor unit emits white mist</b>	In humid regions, a large temperature difference between the room's air and the conditioned air can cause white mist.
<b>Both the indoor and outdoor units emit white mist</b>	When the unit restarts in HEAT mode after defrosting, white mist may be emitted due to moisture generated from the defrosting process.
<b>The indoor unit makes noises</b>	A squeaking sound is heard when the system is OFF or in COOL mode. The noise is also heard when the drain pump (optional) is in operation.
	A squeaking sound may occur after running the unit in HEAT mode due to expansion and contraction of the unit's plastic parts.
<b>Both the indoor unit and outdoor unit make noises</b>	A low hissing sound may occur during operation. This is normal and is caused by refrigerant gas flowing through both the indoor and outdoor units.
	A low hissing sound may be heard when the system starts, has just stopped running or is defrosting. This noise is normal and is caused by the refrigerant gas stopping or changing direction.

Issue	Possible Causes
<b>The outdoor unit makes noises</b>	The unit will make different sounds based on its current operating mode.
<b>Dust is emitted from either the indoor or outdoor unit</b>	The unit may accumulate dust during extended periods of non-use, which will be emitted when the unit is turned on. This can be mitigated by covering the unit during long periods of inactivity.
<b>The unit emits a bad odor</b>	The unit may absorb odors from the environment (such as furniture, cooking, cigarettes, etc.) which will be emitted during operations.
	The unit's filters have become moldy and should be cleaned.
<b>The fan of the outdoor unit does not operate</b>	During operation, the fan speed is controlled to optimize product operation.

**NOTE:** If problem persists, contact a local dealer or your nearest customer service center. Provide them with a detailed description of the unit malfunction as well as your model number.

**When troubles occur, please check the following points before contacting a repair company.**

Problem	Possible Causes	Solution
<b>Poor Cooling Performance</b>	Temperature setting may be higher than ambient room temperature	Lower the temperature setting
	The heat exchanger on the indoor or outdoor unit is dirty	Clean the affected heat exchanger
	The air filter is dirty	Remove the filter and clean it according to instructions
	The air inlet or outlet of either unit is blocked	Turn the unit off, remove the obstruction and turn it back on
	Doors and windows are open	Make sure that all doors and windows are closed while operating the unit
	Excessive heat is generated by sunlight	Close windows and curtains during periods of high heat or bright sunshine
	Low refrigerant due to leak or long-term use	Check for leaks, re-seal if necessary and top off refrigerant

<b>Problem</b>	<b>Possible Causes</b>	<b>Solution</b>
<b>The unit is not working</b>	Power failure	Wait for the power to be restored
	The power is turned off	Turn on the power
	The fuse is burned out	Replace the fuse
	Remote control batteries are dead	Replace batteries
	The Unit's 3-minute protection has been activated	Wait three minutes after restarting the unit
<b>The unit starts and stops frequently</b>	System circuit is blocked	Determine which circuit is blocked and replace the malfunctioning piece of equipment
	There's too much or too little refrigerant in the system	Check for leaks and recharge the system with refrigerant.
	Incompressible gas or moisture has entered the system.	Evacuate and recharge the system with refrigerant
	There is air, incompressible gas or foreign material in the refrigeration system.	Evacuate and recharge the system with refrigerant
	The compressor is broken	Replace the compressor
	The voltage is too high or too low	Install a manostat to regulate the voltage
<b>Poor heating performance</b>	The outdoor temperature is lower than 7°C (44.5°F)	Check for leaks and recharge the system with refrigerant
	Cold air is entering through doors and windows	Make sure that all doors and windows are closed during use
	Low refrigerant due to leak or long-term use	Check for leaks, re-seal if necessary and top off refrigerant

# PACKING AND UNPACKING THE UNIT

Instructions for packing unpacking the unit:

Unpacking:

Indoor unit:

1. Cut the packing belt.
2. Unpack the package.
3. Take out the packing cushion and packing support.
4. Remove the packing film.
5. Take out the accessories.
6. Lift the machine out and lay it flat.

Outdoor Unit

1. Cut the packing belt.
2. Take the unit out of the package.
3. Remove the foam from the unit.
4. Remove the packing film from the unit.

Packing:

Indoor unit:

1. Put the indoor unit into the packing film.
2. Put the accessories in.
3. Place the packing cushion and packing support.
4. Put the indoor unit into the package.
5. Close the package and seal it.
6. Using the packing belt if necessary.

Outdoor unit:

1. Put the outdoor unit into the packing film.
2. Put the bottom foam into the box.
3. Put the outdoor unit into the package, then put the upper packaging foam on the unit.
4. Close the package and seal it.
5. Using the packing belt if necessary.

**NOTE:** Please keep all packaging items if you may need in the future.





The design and specifications are subject to change without prior notice for product improvement. Consult with the sales agency or manufacturer for details. Any updates to the manual will be uploaded to the service website, please check for the latest version.

**QS006UI-YTD(R454B)**

16122300A25231