

Mitsutomo Submittal Data Sheet

R-454B 18K Low Static Slim Duct Hyper Heat Series

Job Name: _____

Engineer: _____

Submitted By: _____

Date: _____

Unit Tag: _____

System Info & Features:

- Slim design
- Up to .4" Static Pressure
- Heating down to -22 deg
- Self diagnostics
- Super quiet
- 7 Day Programmable Wall Thermostat



MODEL NUMBER	
Indoor unit:	HD-UZ18-LA-Q
Outdoor unit:	HO-SZ18-LA-Q
Certified:	

OPTIONAL ACCESSORIES	
3rd Party Thermostat Interface Adapter	17222000A68532

SYSTEM PERFORMANCE AND DATA	
Cooling Efficiencies and Performance	
SEER2	18.0
EER2	12.0
Rated Capacity	17000
Min/Max Capacity	6500~18800
Moisture Removal (L/H)	N/A
Standard Operating Range (F°)	-22~-122(-30~50)
Conditions:	Indoor: 80F° DB/67F° WB Outdoor: 95F° DB/75F° WB
Heating Efficiencies and Performance	
HSPF2-4	10.5
COP	3.37
1. @ 47F° Rated	19000
1. @ 47F° Min/Max Capacity	8900~22000
2. @ 17F° Rated	15000
3. @ 5F° Rated: Capacity / COP	18000/2.00
3. @ 5F° Max: Capacity	18000
Standard Operating Range (F°)	-22~75(-30~24)
1. Conditions:	Indoor: 70F° DB/60F° WB Outdoor: 47F° DB/43F° WB
2. Conditions:	Indoor: 70F° DB/60F° WB Outdoor: 17F° DB/15F° WB
3. Conditions:	Indoor: 70F° DB/60F° WB Outdoor: 5F° DB/5F° WB

SPECIFICATIONS	
Indoor:	
Indoor Air Flow (Turbo/H/M/L/Q) (CFM)	600.4 / 559.2 / 500.3 / 441.4 / 441.4
Indoor Noise Level (Turbo/H/M/L/Q) (DBA)	40 / 40 / 39 / 38 / 32
Heating Efficiencies and Performance	
Compressor Type	ROTARY
Refrigerant	R454B
Refrigerant Oil Charge (OZ)	20.96
Refrigerant Oil	VG74
Outdoor Air Flow (Max) (CFM)	1765.8
Outdoor Noise Level (DBA)	59.0

ELECTRICAL	
Power Supply	208/230V,60Hz,1Ph
System Min. Circuit Amps	19.00
Connection Wiring	14/4
System Max Over Current Protection (A)	20
Compressor (RLA)	11.7
Outdoor Fan Motor (RLA)	0.9
Outdoor Fan Motor (W)	80
Indoor Fan Motor (RLA)	1.2
Indoor Fan Motor (W)	165
System Power Input @ Cooling (W)	1420(310 ~ 1750)
System Power Input @ Heating (W)	1650(550 ~ 2250)

DIMENSIONS	
Indoor:	
Dimension (W×D×H)	34.65 x 26.54 x 8.27
Package (W×D×H)	42.13 x 28.54 x 11.02
Unit Weight (lbs)	54.45
Shipping Weight (lbs)	66.14
Outdoor:	
Dimension (W×D×H)	35.04 x 13.46 x 26.50
Package (W×D×H)	39.17 x 15.67 x 29.13
Unit Weight (lbs)	99.87
Shipping Weight (lbs)	107.80

REFRIGERANT PIPE DATA	
Liquid Size (in.)	1/4
Gas Size (in.)	1/2
Max. Piping Length (ft)	98.40
Max. Height Differencex (ft)	65.60
Max. Pre-charged Length (ft)	24.6
Refrigerant Pre-charged Amount (oz)	55.38
Additional Charge of Refrigerant (oz/ft)	0.16
Connection Method	Flared

WARRANTY	
	5 years compressor 5 years parts

Outdoor Unit Dimension

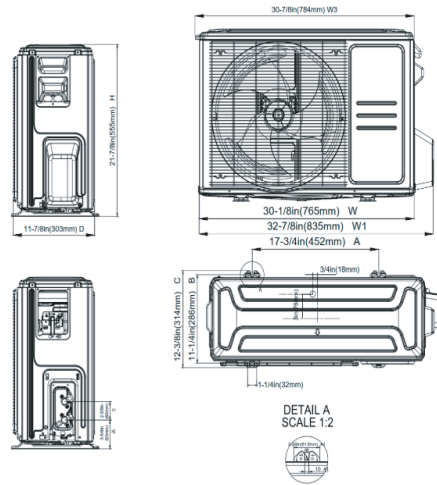

Indoor Unit Dimension (Internal Pump)

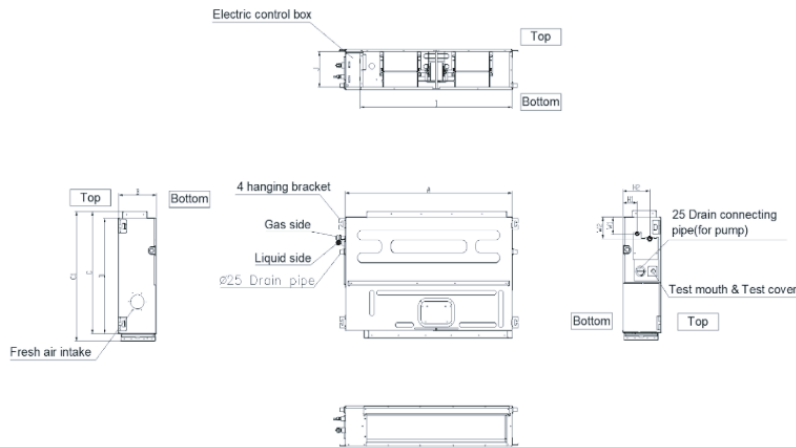

Capacity	A	B	C	C1	D
18K	34 5/8	8 1/4	25	26.5	23 5/8

Indoor Unit Dimension (External Pump)

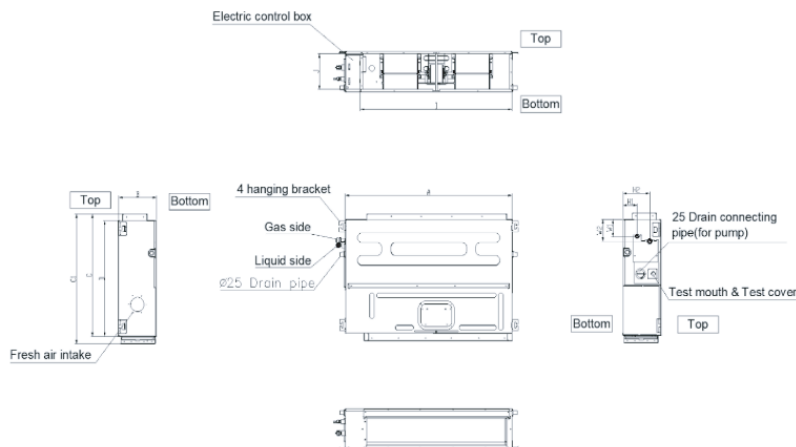

Capacity	A	B	C	C1	D
18K	34 5/8	8 1/4	25	26 1/2	23 5/8