

Mitsutomo Submittal Data Sheet

R-454B 12K Low Static Slim Duct Multi Zone Hyper Heat Series

Job Name: _____

Engineer: _____

Submitted By: _____

Date: _____

Unit Tag: _____

System Info & Features:

- Slim design
- Up to .4" Static Pressure
- Heating down to -22 deg
- Self diagnostics
- Super quiet
- 7 Day Programmable Wall Thermostat

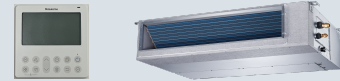

MODEL NUMBER

Indoor unit: HD-UZ12-LA-Q
 Certified:

SYSTEM PERFORMANCE DATA

Electrical:		
Normal Operational Voltage	(V, Ph, Hz)	208/230V, 60Hz, 1Ph
Connection wiring		14/4
Performance Data:		
Rated Capacity		12000
Min/Max Capacity		3400-13500
Moisture Removal	(L/H)	N/A

REFRIGERANT PIPE DATA

Refrigerant Type		R454B
Liquid Side	(inch)	1/4
Gas Side	(inch)	3/8
Connection Method		Flared
Temperature Ratings:		
Indoor (cooling)	(Deg. °F)	-22~122
Indoor (heating)	(Deg. °F)	-22~75

OPTIONAL ACCESSORIES

3rd Party Thermostat Interface Adapter 17222000A68532

INDOOR UNIT DATA

Fan Motor	(RLA)	1.2
Fan Motor	(W)	81
Air Flow & Sound Data:		
Indoor Air Flow (Turbo/H/M/L/Q)	(CFM)	400.2 / 323.7 / 264.9 / 176.6 / 117.7
Indoor Noise Level (Turbo/H/M/L/Q)	(DBA)	36 / 36 / 34.5 / 32.5 / 25.5

Dimensions:

Indoor:		
Dimension (WxDxH)	(inch)	27.56 x 19.92 x 7.87
Packing (WxDxH)	(inch)	33.86 x 21.26 x 11.22
Unit weight	(lbs.)	39.46
Shipping Weight	(lbs.)	46.74

WARRANTY



5 years compressor
5 years parts

Indoor Unit Dimension

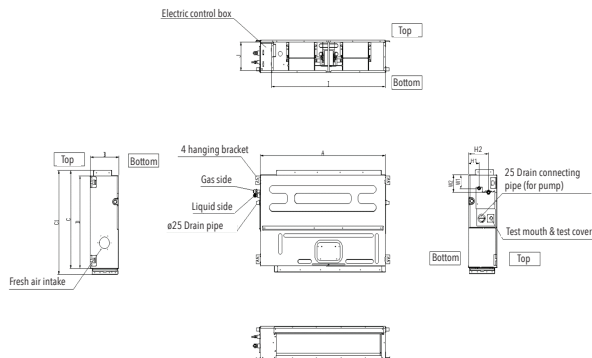

Internal Pump

Capacity	A	B	C	C1	D
12K	27 1/2	7 7/8	18 1/2	20	17 3/4

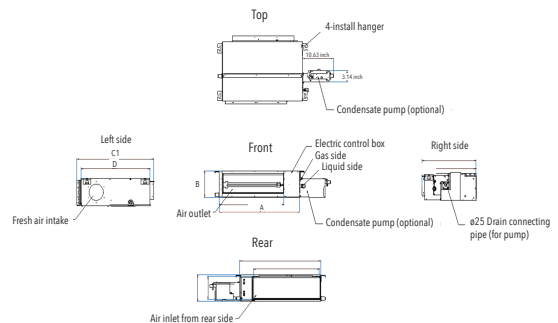

External Pump

Capacity	A	B	C	C1	D
12K	27 1/2	7 7/8	18 1/2	20	17 3/4