

Mitsutomo Submittal Data Sheet

R-454B 18K Low Static Slim Duct Multi Zone Hyper Heat Series

Job Name: _____

Engineer: _____

Submitted By: _____

Date: _____

Unit Tag: _____

System Info & Features:

- Slim design
- Up to .4" Static Pressure
- Heating down to -22 deg
- Self diagnostics
- Super quiet
- 7 Day Programmable Wall Thermostat

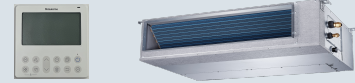

MODEL NUMBER

Indoor unit: **HD-UZ18-LA-Q**

Certified:

OPTIONAL ACCESSORIES

3rd Party Thermostat Interface Adapter **17222000A68532**

SYSTEM PERFORMANCE DATA

Electrical:		
Normal Operational Voltage	(V, Ph, Hz)	208/230V, 60Hz, 1Ph
Connection wiring		14/4
Performance Data:		
Rated Capacity		17000
Min/Max Capacity		6500~18800
Moisture Removal	(L/H)	N/A

INDOOR UNIT DATA

Fan Motor	(RLA)	1.2
Fan Motor	(W)	165
Air Flow & Sound Data:		
Indoor Air Flow (Turbo/H/M/L/Q)	(CFM)	600.4 / 559.2 / 500.3 / 441.4 / 441.4
Indoor Noise Level (Turbo/H/M/L/Q)	(DBA)	40 / 40 / 39 / 38 / 32

Dimensions:

Indoor:		
Dimension (WxDxH)	(inch)	34.65 x 26.54 x 8.27
Packing(WxDxH)	(inch)	42.13 x 28.54 x 11.02
Unit weight	(lbs.)	54.45
Shipping Weight	(lbs.)	66.14

REFRIGERANT PIPE DATA

Refrigerant Type		R454B
Liquid Side	(inch)	1/4
Gas Side	(inch)	1/2
Connection Method		Flared
Temperature Ratings:		
Indoor (cooling)	(Deg. °F)	-22~122
Indoor (heating)	(Deg. °F)	-22~75

WARRANTY



5 years compressor
5 years parts

Indoor Unit Dimension

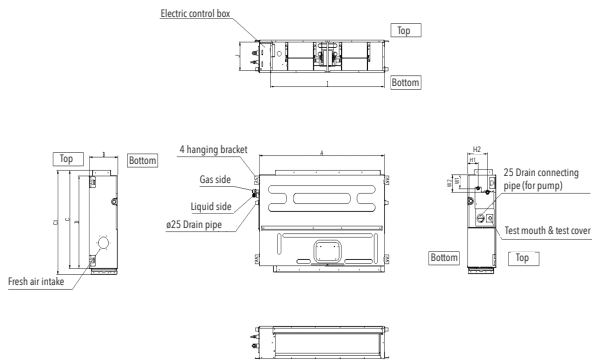

Internal Pump

Capacity	A	B	C	C1	D	
18K	34 5/8	8 1/4	25	26.5	23 5/8	

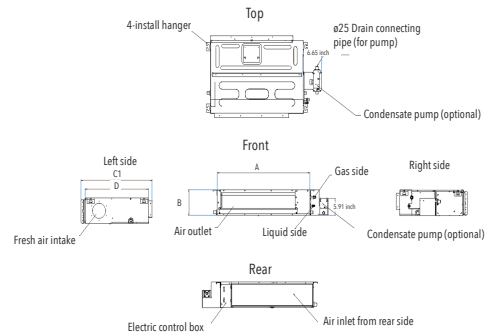

External Pump

Capacity	A	B	C	C1	D	
18K	34 5/8	8 1/4	25	26 1/2	23 5/8	