

Mitsutomo Submittal Data Sheet

R-454B 24K Slim Ducted Multi Zone Evap

Job Name: _____

Engineer: _____

Submitted By: _____

Date: _____

Unit Tag: _____

System Info & Features:

- Slim design
- Up to .8" Static Pressure
- Heating down to -22 deg
- Self diagnostics
- Super quiet
- 7 Day Programmable Wall Thermostat

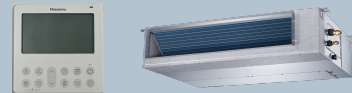

MODEL NUMBER	
Indoor unit:	HD-UZ24-LA-Q
Certified:	   

OPTIONAL ACCESSORIES	
3rd Party Thermostat Interface Adapter	17222000A68532

SYSTEM PERFORMANCE DATA		
Electrical:		
Normal Operational Voltage	(V, Ph, Hz)	208/230V,60Hz,1Ph
Connection wiring		14/4
Performance Data:		
Rated Capacity		24000
Min/Max Capacity		5000~28000
Moisture Removal	(L/H)	2.03

INDOOR UNIT DATA		
Fan Motor	(RLA)	2.2
Fan Motor	(W)	165
Air Flow & Sound Data:		
Indoor Air Flow (Turbo/H/M/L/Q)	(CFM)	853.5 / 706.3 / 618.0 / 500.3 / 500.3
Indoor Noise Level (Turbo/H/M/L/Q)	(DBA)	40 / 40 / 37 / 35 / 29.5

REFRIGERANT PIPE DATA		
Refrigerant Type		R454B
Liquid Side	(inch)	3/8
Gas Side	(inch)	5/8
Connection Method		Flared
Temperature Ratings:		
Indoor (cooling)	(Deg. °F)	-22~122
Indoor (heating)	(Deg. °F)	-22~75

Dimensions:		
Indoor:		
Dimension (WxDxH)	(inch)	39.37 x 29.53 x 9.65
Packing(WxDxH)	(inch)	48.23 x 33.86 x 11.97
Unit weight	(lbs.)	80.47
Shipping Weight	(lbs.)	91.93

WARRANTY	
	5 years compressor 5 years parts

Indoor Unit Dimension

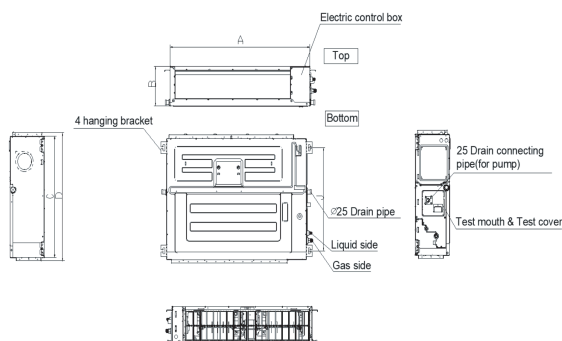

Capacity	W	D	H
24k	39.37	29.53	9.65